

The data to be read in conjunction with the Hydrogen Thyatron Preamble.

ABRIDGED DATA

Electrically identical to the CX1140LG.

Deuterium-filled, fast recovery, tetrode thyatron, specifically designed for operation under medical linac conditions. A reservoir operating from the cathode heater supply is incorporated.

| | | |
|----------------------------|---|------------|
| Peak forward anode voltage | - | 33 kV max |
| Peak anode current | - | 1000 A max |
| Average anode current: | | |
| Continuous operation | - | 1.25 A max |
| Intermittent operation | - | 2.2 A max |

GENERAL DATA

Electrical

| | | |
|---|---|------------------------|
| Cathode (connected internally to mid-point of the heater) | - | Oxide coated |
| Heater voltage | - | 6.3 + 0.2 V - 0.3 V |
| Heater current | - | 22 A |
| Tube heating time (minimum) | - | 5.0 min |

Mechanical

| | | |
|--------------------------------|---|--|
| Overall length | - | 317.5 mm (12.500 inches) max |
| Overall diameter | - | 84.12 mm (3.312 inches) max |
| Net weight | - | 0.7 kg (1.5 pounds) approx. |
| Mounting position (see note 1) | - | Any |
| Base | - | Pin spacing as B5F 3 locations for fixing clips |
| Top cap (see note 2) | - | BS448-CT3 |

| | | |
|----------------|---|---------|
| Cooling | - | Natural |
|----------------|---|---------|

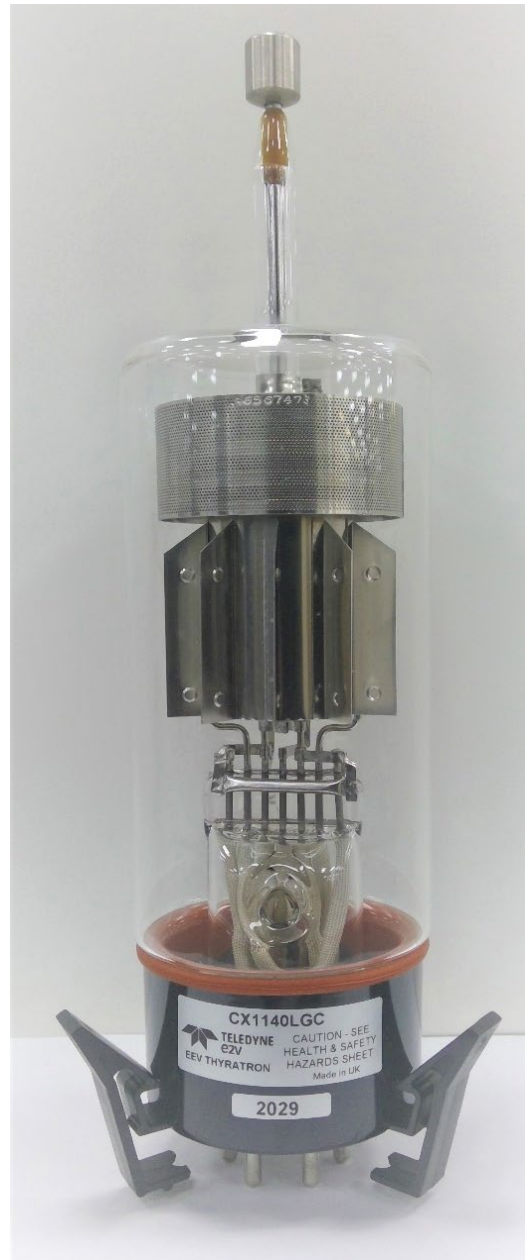

Whilst Teledyne e2v has taken care to ensure the accuracy of the information contained herein it accepts no responsibility for the consequences of any use thereof and also reserves the right to change the specification of goods without notice. Teledyne e2v accepts no liability beyond that set out in its standard conditions of sale in respect of infringement of third party patents arising from the use of tubes or other devices in accordance with information contained herein.

Teledyne UK Limited, Waterhouse Lane, Chelmsford, Essex CM1 2QU United Kingdom Teledyne UK Ltd. is a Teledyne Technologies company.

Telephone: +44 (0)1245 493493 Facsimile: +44 (0)1245 492492

Contact Teledyne e2v by e-mail: Enquiries@Teledyne-e2v.com or visit www.teledyne-e2v.com for global sales and operations centres.

PULSE MODULATOR SERVICE

MAXIMUM AND MINIMUM RATINGS (Absolute values)

| Anode | Min | Max | |
|--|-----|------|------|
| Peak forward anode voltage (see note 3) | - | 33 | kV |
| Peak inverse anode voltage (see note 4) | - | 33 | kV |
| Peak anode current | - | 1000 | A |
| Peak anode current (pulse repetition rate limited to 60 pps max) | - | 2000 | A |
| Average anode current: Continuous operation | - | 1.25 | A |
| Intermittent operation | - | 2.2 | A |
| Rate of rise of anode current (see note 5) | - | 5000 | A/μs |

| Grid 2 | Min | Max | |
|---|-----|------|-------|
| Unloaded grid 2 drive pulse voltage (see note 6) | 500 | 1000 | V |
| Grid 2 pulse duration | 1.0 | - | μs |
| Rate of rise of grid 2 pulse (see note 5) | 1.0 | - | kV/μs |
| Grid 2 pulse delay | 0.5 | 3.0 | μs |
| Peak inverse grid 2 voltage | - | 450 | V |
| Loaded grid 2 bias voltage | 0 | -150 | V |
| Grid 2 drive impedance | 50 | 500 | Ω |
| Grid 2 bias impedance | 30 | 50 | kΩ |

| Grid 1 – DC Primed (see note 7) | Min | Max | |
|---------------------------------------|-----|-----|----|
| DC grid 1 unloaded priming voltage | 75 | 150 | V |
| DC grid 1 priming current | 50 | 100 | mA |

| Grid 1 – Pulsed (see note 7) | Min | Max | |
|---|------------|------|-------|
| Unloaded grid 1 drive pulse voltage (see note 6) | 300 | 1000 | V |
| Grid 1 pulse duration | 2.0 | - | μs |
| Rate of rise of grid 1 pulse (see note 5) | 1.0 | - | kV/μs |
| Peak inverse grid 1 voltage | - | 450 | V |
| Loaded grid 1 bias voltage | See note 8 | | |
| Peak grid 1 drive current | 0.3 | 1.0 | A |

| Cathode | Min | Max | |
|-------------------|-----|--------------|-----|
| Heater voltage | 6.3 | +0.2 -0.3 | V |
| Tube heating time | 5.0 | - | min |

| Environmental | Min | Max | |
|---------------------|-----|-------------|----------|
| Ambient temperature | -50 | +90 | °C |
| Altitude | - | 3 10,000 | km ft |

CHARACTERISTICS

| | Min | Typ | Max | |
|--|-------------------|------|------|----|
| Critical DC anode voltage for conduction (see note 9) | - | 0.5 | 2.0 | kV |
| Anode delay time (see notes 9 and 10) | - | 0.15 | 0.25 | μs |
| Anode delay drift time (see notes 9 and 11) | - | 20 | 50 | ns |
| Time jitter (see note 9) | - | 1.0 | 5.0 | ns |
| Recovery time | See graph, page 5 | | | |
| Heater current (at 6.3 V) | 18 | 22 | 25 | A |

RATINGS FOR FAULT CONDITIONS, SINGLE-SHOT OR CROWBAR SERVICE

| | | |
|---|---|----------------------|
| DC forward anode voltage | - | 30 kV max |
| Peak anode current | - | 10,000 A max |
| Product of peak current and pulse duration | - | 0.6 A.s max |
| Repetition frequency | - | 1 pulse per 10 s max |

NOTES

1. Clamping is only permissible by the base.
2. A large area anode connector, Teledyne e2v type MA360, is recommended.
3. The maximum permissible peak forward voltage for instantaneous starting is 33 kV and there must be no overshoot.
4. The peak inverse voltage must not exceed 10 kV for the first 25 μ s after the anode pulse.
5. This rate of rise refers to that part of the leading edge of the pulse between 25% and 75% of the pulse amplitude.
6. Measured with respect to cathode. In certain cases the maximum drive pulse voltage may be exceeded without damage to the tube; a maximum value of 2.5 kV is then recommended. When grid 1 is pulse driven, the last 0.25 μ s of the top of the grid 1 pulse must overlap the corresponding first 0.25 μ s of the top of the delayed grid 2 pulse.
7. DC priming is recommended for crowbar service. Grid 1 pre-pulsing is recommended for operating conditions requiring minimum anode delay time drift and minimum jitter.
8. DC negative bias voltages must not be applied to grid 1. When grid 1 is pulse driven, the potential of grid 1 may vary between -10 and +5 V with respect to cathode potential during the period between the completion of recovery and the commencement of the succeeding grid pulse.
9. Typical figures are obtained on test using conditions of minimum grid drive (pre-pulse on grid 1).
10. The time interval between the instant at which the rising unloaded grid 2 pulse reaches 25% of its pulse amplitude and the instant when anode conduction takes place.
11. The drift in delay time over a period from 10 seconds to 10 minutes after reaching full voltage.

MA91C SOCKET

The MA91C, available from Teledyne-e2v, is a 5-contact socket assembly fitted with terminal tags for the attachment of heater, grid and cathode connecting cables.



MA91C SECURING CLIPS

CX1140LGC includes 3 securing clips attached by M3 fixing screws to the base of the thyatron.

These clips are designed to enhance mechanical security in any application where the circular socket type MA91C is used.

The clips can be removed or attached using a cross head screwdriver



Other Socket Types

Always remove the clips before attempting to install CX1140LGC in any other socket type, including older equipment which has a square ceramic socket.

Installation in MA91C

- Hold the Thyatron only by the glass body close to the base. Do not apply any force to the anode connection.
- Align base pins of the Thyatron with the socket receptacles
- Squeeze all three clips inwards towards Thyatron base until feet clear MA91C whilst inserting the Thyatron as normal.
- Release clips to secure around MA91C socket as shown below



Removal instructions

- Disconnect anode lead
- Hold the Thyatron by the glass body close to the base
- Squeeze all 3 clips clear of MA91C whilst removing thyatron from socket
- Undo screws to remove clips.

MAXIMUM RECOVERY CHARACTERISTICS

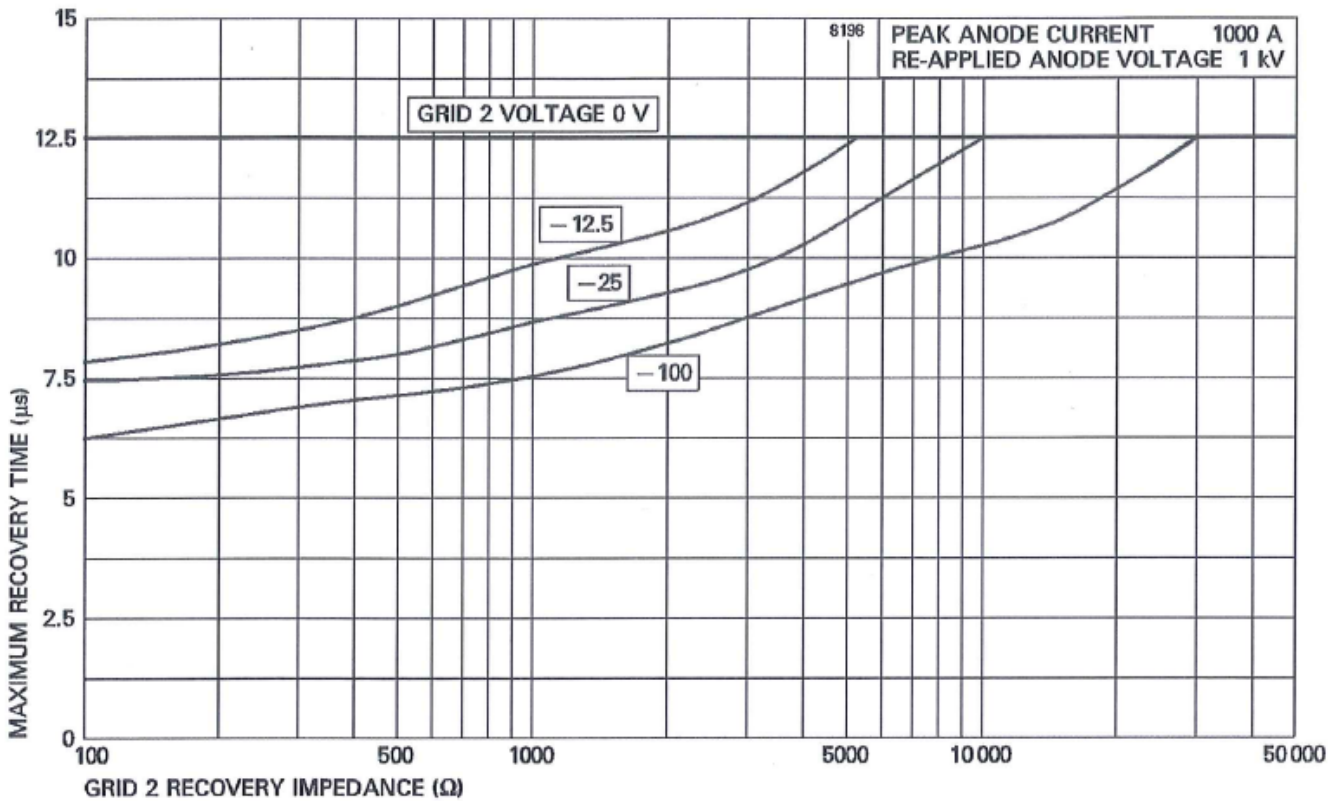

HEALTH AND SAFETY HAZARDS

Teledyne e2v thyratrons are safe to handle and operate, provided that the relevant precautions stated herein are observed. Teledyne e2v does not accept responsibility for damage or injury resulting from the use of electronic devices it produces. Equipment manufacturers and users must ensure that adequate precautions are taken. Appropriate warning labels and notices must be provided on equipment incorporating Teledyne e2v devices and in operating manuals.



High Voltage

Equipment must be designed so that personnel cannot come into contact with high voltage circuits. All high voltage circuits and terminals must be enclosed and fail-safe interlock switches must be fitted to disconnect the primary power supply and discharge all high voltage capacitors and other stored charges before allowing access. Interlock switches must not be bypassed to allow operation with access door open.



X-Ray Radiation

All high voltage devices produce X-rays during operation and may require shielding. The X-ray radiation from hydrogen thyratrons is usually reduced to a safe level by enclosing the equipment or shielding the thyatron with at least 1.6 mm (1/16 inch) thick steel panels.

Users and equipment manufacturers must check the radiation level under their maximum operating conditions.

OUTLINE CX1140LGC

(All dimensions without limits are nominal)

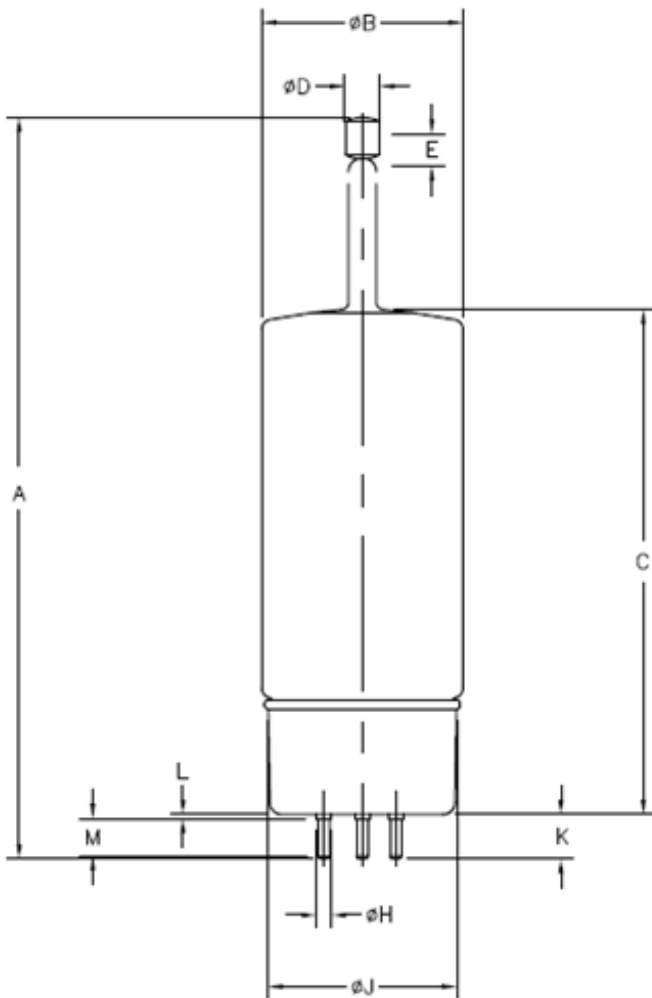

| Ref | Millimetres | Inches |
|-----|--------------|----------------|
| A | 304.8 ± 12.7 | 12.000 ± 0.500 |
| B | 84.12 max | 3.312 max |
| C | 215.9 ± 12.7 | 8.500 ± 0.500 |
| D | 14.38 ± 0.18 | 0.566 ± 0.008 |
| E | 12.7 min | 0.500 min |
| F | 4.75 ± 0.08 | 0.187 ± 0.003 |
| G | 31.75 | 1.250 |
| H | 6.6 max | 0.260 max |
| J | 77.77 ± 1.57 | 3.062 ± 0.062 |
| K | 19.56 max | 0.770 max |
| L | 1.85 max | 0.073 max |
| M | 14.6 min | 0.575 min |

Inch dimensions have been derived from millimetres

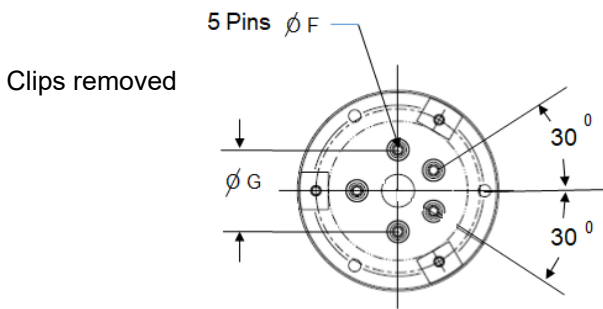
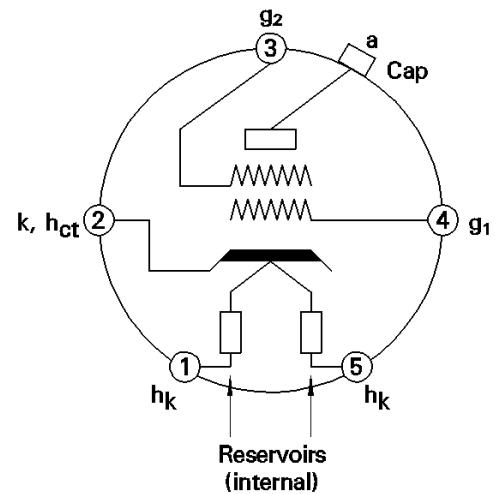

Clips attached

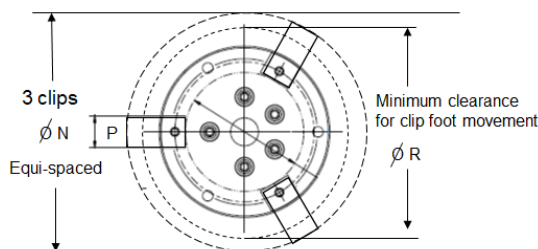

| Pin | Element |
|---------|---|
| 1 | Heater |
| 2 | Cathode, connected internally to heater mid-point |
| 3 | Grid 2 |
| 4 | Grid 1 |
| 5 | Heater |
| Top cap | Anode |

| Ref | Millimetres | Inches |
|-----|-------------|--------|
| N | 125 | 4.9 |
| P | 14.5 | 0.6 |
| R | 110 | 4.33 |

Inch dimensions have been derived from millimetres

OUTLINE MA91C

(All dimensions without limits are nominal)

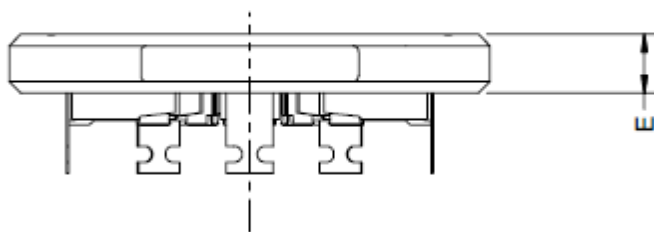
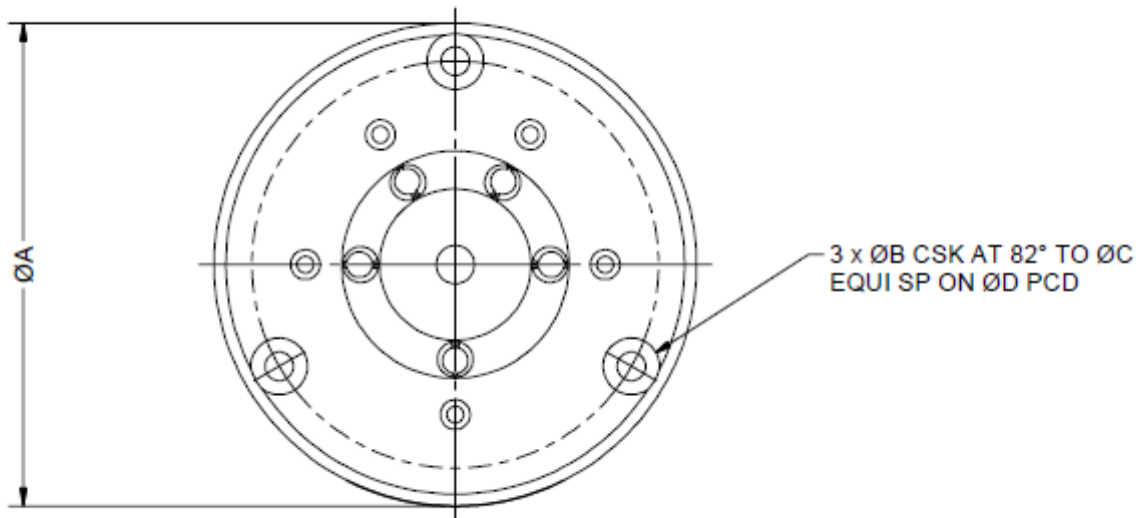

| REF. | MILLIMETRES | INCHES |
|------|-------------|--------|
| A | 81.00 | 3.189 |
| B | 4.80 | 0.189 |
| C | 9.50 | 0.374 |
| D | 68.25 | 2.687 |
| E | 10.00 | 0.394 |

INCH DIMENSIONS HAVE BEEN DERIVED FROM MILLIMETRES.