

FEATURES

- Replaces Maxwell PC5-5
- Over 500,000 duty cycles
- 10-year life capability
- Hermetically sealed, stainless steel construction
- Linear voltage balanced cells
- Higher energy vs. electrolytic
- Higher power vs. batteries

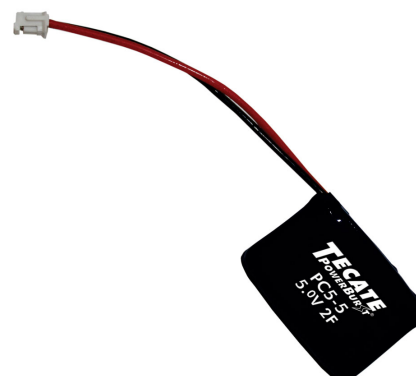

APPLICATIONS

- Automatic meter readers
- Automotive subsystems
- Backup power for soft shutdown requirements
- Digital cameras and other consumer electronics
- Wireless transmissions

GENERAL SPECIFICATIONS

Item	Performance
Operating temperature	-40°C to +65°C
Storage temperature	-40°C to +85°C
Capacitance	2F
Capacitance tolerance	±20%
Rated voltage	5 VDC
Endurance (At rated voltage & max. operating temp)	After 1000 hours: Capacitance change: Within ±20% of initial measured value Internal resistance: Within ±40% of initial specified value
Projected Load life (At rated voltage & 25°C)	After 10 years: Capacitance change: Within ±20% of initial measured value Internal resistance: Within 2 times of initial specified value
Projected cycle life (From rated voltage to 1/2 rated voltage at 25°C)	After 500,000 cycles: Capacitance change: Within ±20% of initial measured value Internal resistance: Within 2 times of initial specified value

DIMENSIONS

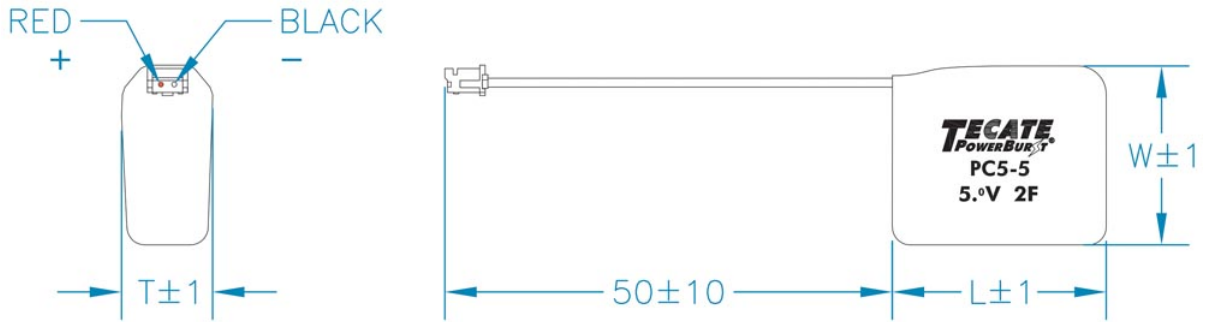

STANDARD PRODUCTS

Part Number	Nom. Cap. (F)	ESR DC (mΩ)	ESR AC (mΩ) (1 KHz)	Leakage Current (mA) (72 hrs @ 25C)	Dimensions (mm)			Weight/Unit (grams)
					L	W	T	
PC5-5	2	1000	725	0.02	24	18	11	8