



Ultracapacitor Energy Storage Cabinet Up to 10 Ultracapacitor Cellpacks

- Innovative in Energy Storage & Power Electronics
- Custom-made solutions
- Complete storage, power electronics & system integration solutions available

Features

- Flexible configuration possible for modules in series or parallel
- Cost-effective in kW/m³
- Diagnostic interface via fiber optics
- Voltage and temperature monitoring and balancing of every individual cell
- High capacity and low internal resistance

Applications

- Pulsed current source
- Braking energy recuperation systems
- Stabilization of power grids
- Peak shaving

Configuration opportunities

- Number of possible modules per cabinet: 6 to 8 (with MCU and electrical controls) and up to 10 (only Cell Pack modules in one cabinet).

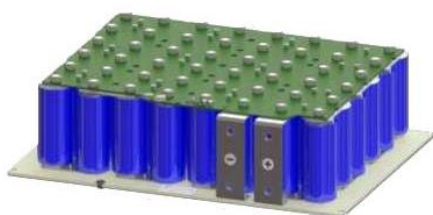

Figure 1: Standard Cell Pack
Low cost version for stationary applications in buildings.

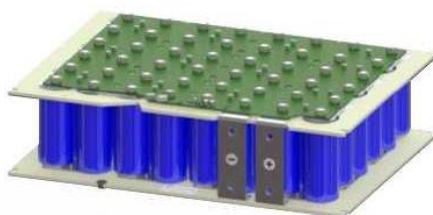

Figure 2: Vibration Proof (VP) Cell Pack
Mobile applications like cranes and ships.



Figure 3: Vibration Proof with safety plate (VPS)
Additional protection for the electronics



Typical Characteristics

Type VP with 48 cells and 6 Cell Packs

Symbol	Parameter	Description	Value	Unit
	Capacity			
C_r	Rated capacity		10,42	F
	Tolerance		+20/-0	%
	Voltage			
V_r	Max. voltage	Monitoring from 30V to UDCmax	780	VDC
V_{max}	Max. operating voltage		750	VDC
V_{MN}	Isolation voltage	Max. voltage at base isolation	1800	VDC
	Internal resistance			
ESR,DC	Equivalent series resistance DC	@25°C (initial...lifetime)	54...168	mΩ
ESR,AC	Equivalent series resistance AC	@25°C and 1 kHz (initial)	66	mΩ
	Environment			
T_n	Operating temperature range		0 till 40	°C
$T_{storage}$	Storage temperature range		-20 till 50	°C
	Protection degree	Cabinet open or closed	IP20	
	Energy			
E_{max}	Energy density	@ V_r	26,4	Wh/kg
E_{ava}	Usable energy	Between V_r and $\frac{1}{2} V_r$	660	Wh
	Current			
I_r	Rated current	Continuous	150	A rms
	Peak current	< 5 sec.	1500	A
I_{leak}	Leakage current	After 72 hours @25°C and V_r (only the cells)	5,2	mA
	Lifetime			
	Projected cycle life	Between V_r and $\frac{1}{2} V_r$ @25°C	1.000.000	
	Projected DC life	@ V_r and 25°C @ V_r and 65°C	10 1500	a h
	Mechanical data for 6 Cell Pack Modules			
	Weight		±500	kg
	Width		800	mm
	Depth		600	mm
	Height		2000	mm

System diagram of the ESS cabinet

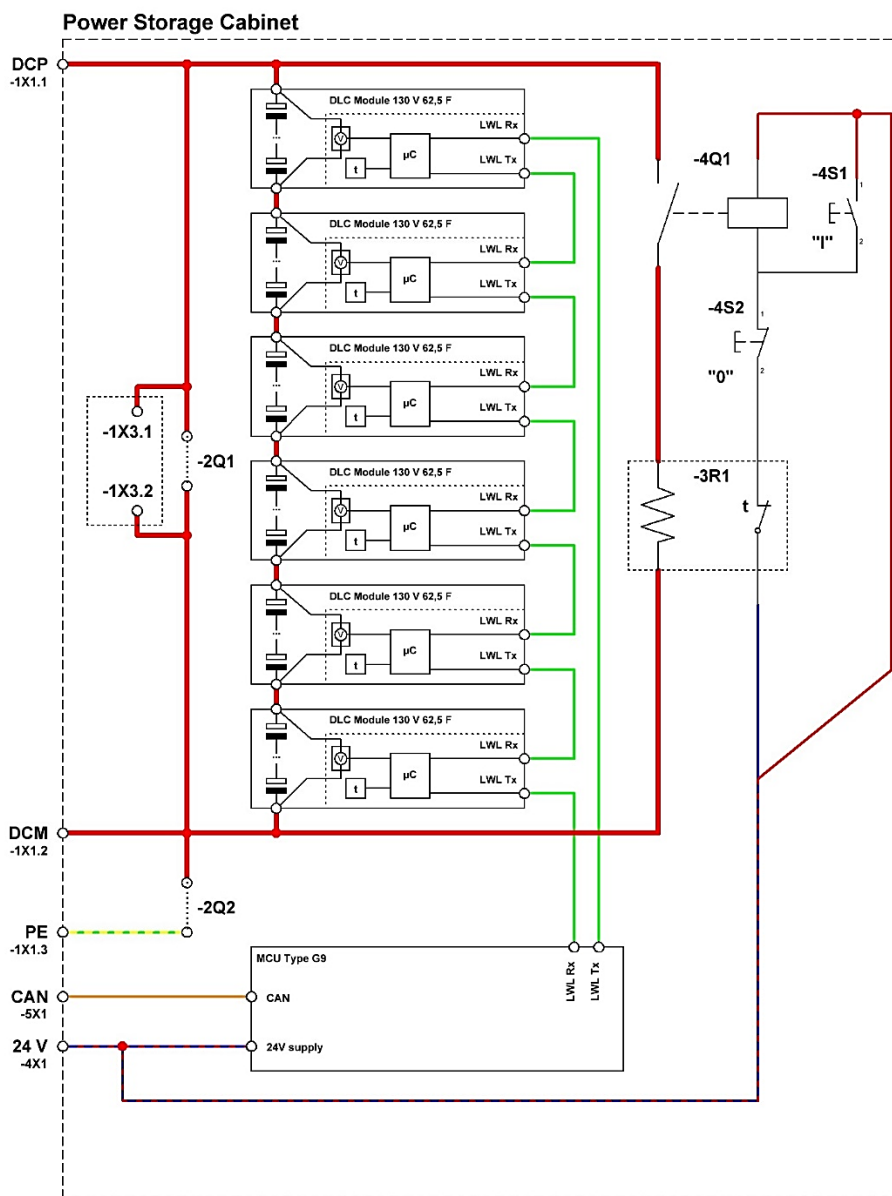

- Power line
- PE
- LWL
- Field Bus
- Signal Line
- Power Supply
- ····· ○ NH solid link

Figure 4: System cabinet diagram with 6 DLC Modules.

Example of electronic components layout of the cabinet with 6 Cell Packs



Figure 5: Example of electronic components layout

No.	Description
1	Monitoring Control Unit (MCU)
2	CAN-Bus connector
3	AC supply terminals
4	DC power terminals
5	Fan control unit
6	Discharge NH solid link sockets
7	DC power terminals
8	Discharge test socket for DMM
9	Discharge push button switches
10	Discharge contactor

ESS overview of possible cabinet sizing and output voltages

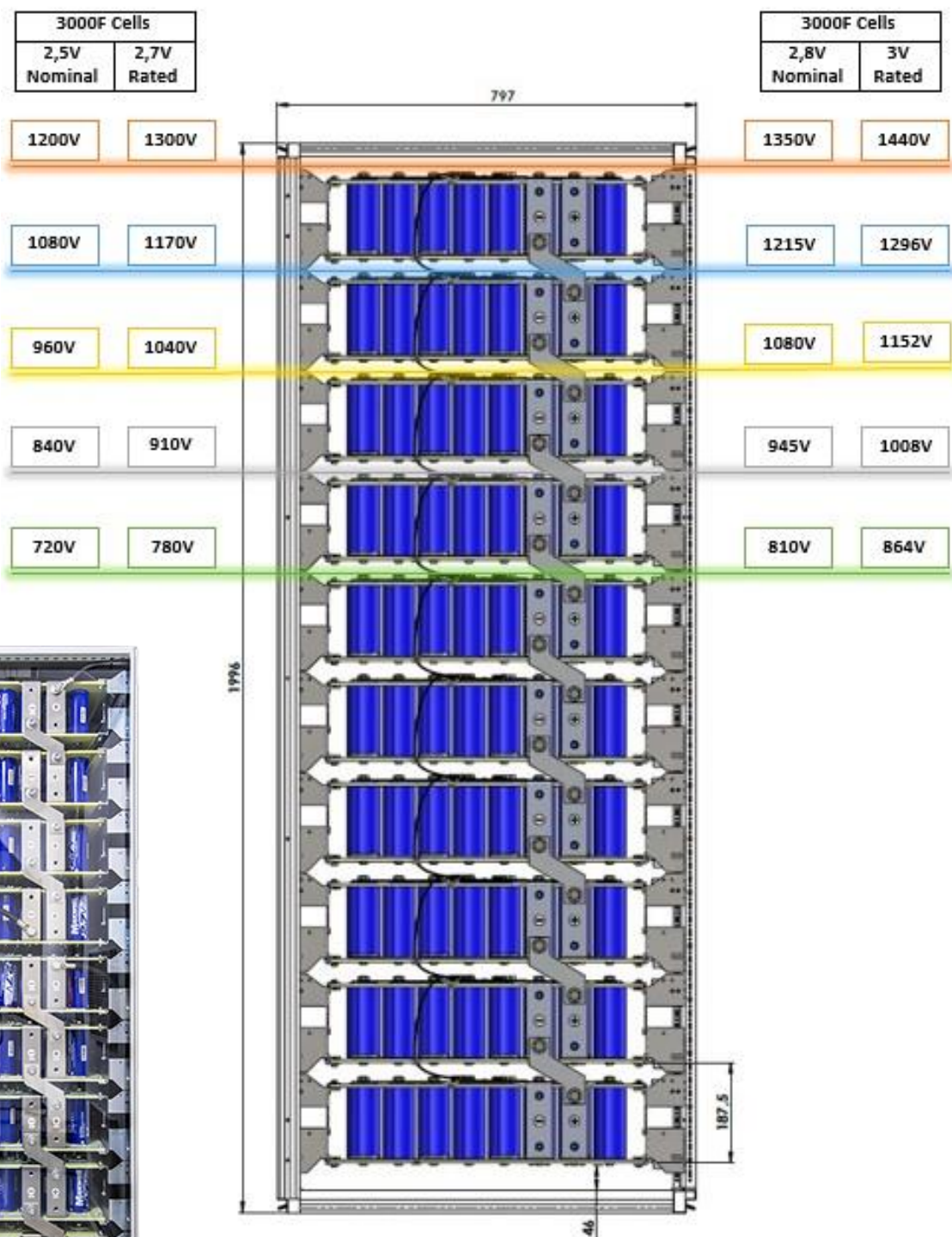

Figure 6: Cell Pack voltage at 2,5V and 2,7V per cell

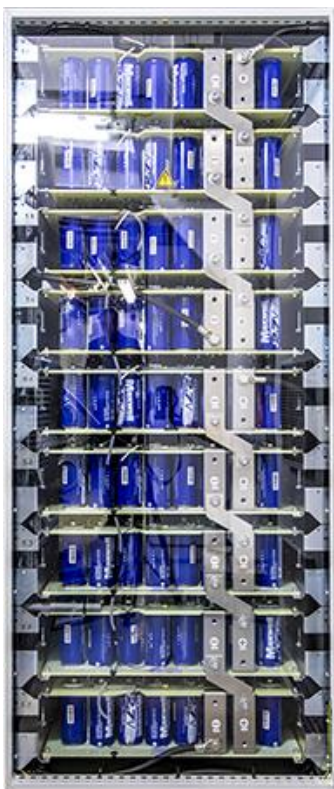

Figure 7: Example of a ESS with 9 Cell Pack Modules