

E2V Technologies

CX1648, CX1648X Oil Cooled, Deuterium-Filled, Two-Gap Metal/Ceramic Thyatron

The data to be read in conjunction with the Hydrogen Thyatron Preamble.

ABRIDGED DATA

Solid anode, deuterium-filled two-gap thyatron with metal envelope, suitable for switching high peak and average power at high pulse repetition rates. A reservoir operating from the cathode heater supply or a separate supply is incorporated.

The CX1648X, which must be used in conjunction with E2V Technologies resistor box MA942A, permits a larger variation in internal deuterium pressure than the CX1648. Resistor box settings and/or reservoir heater voltage can be adjusted within the specified limits to obtain the maximum thyatron gas pressure consistent with the required voltage hold-off.

Peak forward anode voltage	50	kV max
Peak forward anode current	10	kA max
Average anode current	10	A max
Peak output power	350	MW max
Operating frequency (see note 1)	5	kHz max

GENERAL

Electrical

Cathode	barium aluminate impregnated tungsten	
Cathode heater voltage (see note 2)	$6.3 \pm 5\%$	V
Cathode heater current	90	A
Reservoir heater voltage (see notes 2 and 3)	$6.3 \pm 5\%$	V
Reservoir heater current	7.0	A
Tube heating time (minimum)	10	min
Anode to gradient grid capacitance	45	pF
Gradient grid to grid 2 capacitance	45	pF

Mechanical

Seated height	318 mm (12.520 inches)	nom
Clearance required below mounting flange	75 mm (2.953 inches)	min
Overall diameter	152.4 mm (6.000 inches)	nom
Net weight	10.6 kg (23.4 pounds)	approx
Mounting position	(see note 4)	
Tube connections	see outline	

Cooling

The tube must be cooled by total liquid immersion, for example in force circulated transformer oil (see E2V Technologies Technical Reprint No. 108 'The cooling of oil-filled electrical equipment, with special reference to high power line-type pulse generators' by G. Scoles). Care must be taken to ensure that air is not trapped inside the tube end cover.



PULSE MODULATOR SERVICE MAXIMUM AND MINIMUM RATINGS

These ratings cannot necessarily be used simultaneously, and no individual rating must be exceeded.

	Min	Max	
Anode			
Peak forward anode voltage (see note 5)	-	50	kV
Peak inverse anode voltage		see note 6	
Peak forward anode current	-	10	kA
Average anode current	-	10	A
Rate of rise of anode current		see notes 7 and 8	

Triggering

For maximum life and minimum grid spike, these thyratrons should be triggered with a pre-pulse on grid 1.

	Min	Max	
Grid 2			
Unloaded trigger pulse voltage (see note 9)	1000	2000	V
Trigger pulse duration	1.0	-	μs
Rate of rise of trigger pulse (see notes 7 and 10)	10.0	-	kV/μs
Trigger pulse delay (see note 11)	0.5	3.0	μs
Peak inverse trigger voltage	-	450	V
Loaded trigger pulse bias voltage	-50	-200	V
Peak trigger pulse drive current	5.0	40	A

Grid 1 Pre-pulse (See note 12)

Unloaded drive pulse voltage	600	2000	V
Grid 1 pulse duration	2.0	-	μs
Rate of rise of grid 1 pulse	1.0	-	kV/μs
Peak inverse grid 1 voltage	-	450	V
Loaded grid 1 bias voltage		see note 13	
Peak grid 1 drive current	5.0	40	A

Grid 1 DC Priming

DC grid 1 unloaded priming voltage	75	150	V
DC grid 1 priming current	0.5	2.0	A

Cathode

Heater voltage	6.3 ± 5%		V
Heating time	10	-	min

Reservoir

Heater voltage	6.3 ± 5%		V
Heating time	10	-	min

Environmental

Ambient air temperature	0	40	°C
-------------------------	---	----	----

CHARACTERISTICS

	Min	Typical	Max	
Critical DC anode voltage				
for conduction	-	-	2.0	kV
Anode delay time	-	200	350	ns
Anode delay time drift (see note 14)	-	15	25	ns
Time jitter (see note 15)	-	3.0	10	ns
Recovery time (see notes 1 and 16)	-	20	-	μs
Cathode heater current (at 6.3 V)	80	90	100	A
Reservoir heater current (at 6.3 V)	6.0	7.0	8.0	A

NOTES

- The CX1648/CX1648X has a short recovery time for a tube of its size. The amount of time available for thyatron recovery must be maximised by circuit design, and reliable operation may necessitate the use of command charging techniques. The amount of time required for recovery is affected by gas pressure, peak current, pulse duration and load mismatch.
- It is recommended that the cathode heater and the reservoir heater are supplied from independent power supplies. **The common connection for these two supplies is the pair of yellow sleeved leads, not the cathode flange.**

N.B. The tube will suffer irreversible damage if the cathode flange is connected as the common point.

The cathode heater supply must be connected between the cathode flange and the cathode heater lead (yellow sleeve), the reservoir heater supply must be connected between the cathode heater lead (yellow sleeve) and the reservoir heater lead (red sleeve), see Figs. 1 and 2. In order to meet the jitter specification, it may be necessary in some circumstances that the cathode heater be supplied from a DC source.

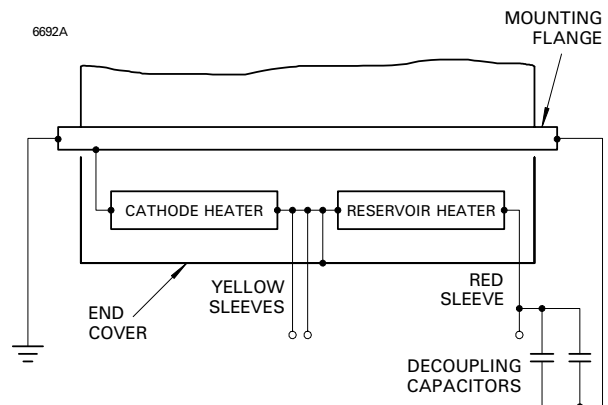

Fig. 1 CX1648 base connections

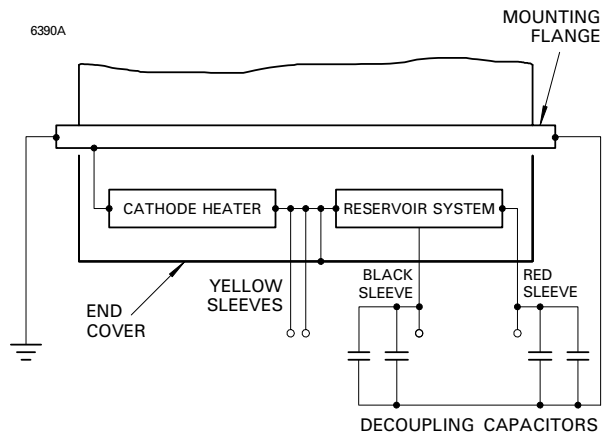

Fig. 2 CX1648X base connections

Care should be taken to ensure that excessive voltages are not applied to the reservoir heater circuit from the cathode heater supply because of high impedance cathode heater connections. For example, in the worst case, an open circuit heater lead will impress almost double voltage on the reservoir heater, especially on switch-on, when the cathode heater impedance is minimal.

This situation can be avoided by ensuring that the two supplies are in anti-phase. The reservoir heater circuit must be decoupled with suitable capacitors, for example, a 1 μF capacitor in parallel with a low inductance 1000 pF capacitor (see schematic drawing on page 4).

The heater supply systems should be connected directly between the cathode flange and the heater leads. This avoids the possibility of injecting voltages into the cathode and reservoir heaters. At high rates of rise of anode current, the cathode potential may rise significantly at the beginning of the pulse, depending on the cathode lead inductance, which must be minimised at all times.

If a single transformer is used to supply both the cathode heater and the reservoir heater, then the reservoir heater lead (red sleeve) must be connected to the mounting flange.

3. CX1648X gas pressure may be altered using E2V Technologies resistor box type MA942A. The CX1648X **must** be used in conjunction with the MA942A. The resistor box must be connected between the gas pressure control lead (black sleeve) and the cathode heater leads (yellow sleeves). Gas pressure may be increased by increasing the resistor box settings from their initial recommended values which accompany each delivered CX1648X. The gas pressure may be increased to a value consistent with the required forward hold-off voltage. Additional variations in gas pressure can be achieved by altering the reservoir heater supply voltage within the specified range.
4. The tube must be fitted using its mounting flange, with flexible connections to all other electrodes. The preferred orientation is with the tube axis vertical and anode uppermost; mounting the tube with its axis horizontal is permissible. It is **not** recommended that the tube is mounted with its axis vertical and cathode uppermost.
5. The maximum permissible peak forward voltage for instantaneous starting is 40 kV and there must be no overshoot.
6. The peak inverse voltage including spike must not exceed 10 kV for the first 25 μs after the anode pulse. Amplitude and rate of rise of inverse voltage contribute greatly to tube

dissipation and electrode damage; if these are not minimised in the circuit, tube life will be shortened considerably. The aim should be for an inverse voltage of 3 – 5 kV peak with a rise time of 0.5 μs .

7. This rate of rise refers to that part of the leading edge of the pulse between 25% and 75% of the pulse amplitude.
8. For single-shot or burst mode applications this parameter can exceed 100 kA/ μs . The ultimate value which can be attained depends to a large extent upon the external circuit.
9. Measured with respect to cathode.
10. A lower rate of rise may be used, but this may result in the anode delay time, delay time drift and jitter exceeding the limits quoted.
11. If grid 1 is pulsed, the last 0.25 μs of the top of the grid 1 pulse must overlap the corresponding first 0.25 μs of the top of the delayed trigger pulse.
12. The optimum grid 1 pulse current is the maximum value which can be applied without causing the tube to trigger before the grid 2 pulse is applied. This value is variable depending on gas pressure, maximum forward anode voltage, grid 2 negative bias voltage, peak current and repetition rate.
13. DC negative bias must not be applied to grid 1.
14. Measured between the second minute after the application of HT and 30 minutes later.
15. A time jitter of less than 1 ns can be obtained if the cathode heater voltage is supplied from a DC source, by adopting double pulsing and applying a grid 2 pulse with a rate of rise of voltage (unloaded) in excess of 20 kV/ μs .
16. Measured after a current pulse of 1000 A, with a grid 2 bias voltage of -100 V , a recovery impedance of 500 Ω and a 1.0 kV anode probe.

HEALTH AND SAFETY HAZARDS

E2V Technologies hydrogen thyratrons are safe to handle and operate, provided that the relevant precautions stated herein are observed. E2V Technologies does not accept responsibility for damage or injury resulting from the use of electronic devices it produces. Equipment manufacturers and users must ensure that adequate precautions are taken. Appropriate warning labels and notices must be provided on equipments incorporating E2V Technologies devices and in operating manuals.



High Voltage

Equipment must be designed so that personnel cannot come into contact with high voltage circuits. All high voltage circuits and terminals must be enclosed and fail-safe interlock switches must be fitted to disconnect the primary power supply and discharge all high voltage capacitors and other stored charges before allowing access. Interlock switches must not be bypassed to allow operation with access doors open.



X-Ray Radiation

All high voltage devices produce X-rays during operation and may require shielding. The X-ray radiation from hydrogen thyratrons is usually reduced to a safe level by enclosing the equipment or shielding the thyratron with at least 1.6 mm ($1/16$ inch) thick steel panels.

Users and equipment manufacturers must check the radiation level under their maximum operating conditions.

CX1648 SCHEMATIC DIAGRAM

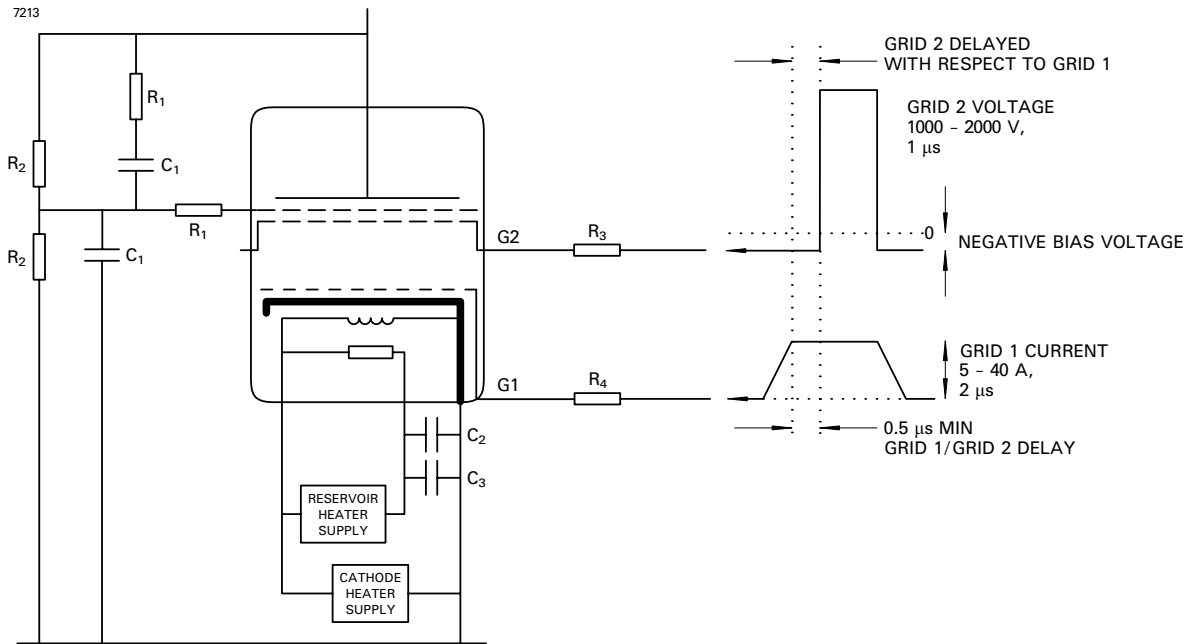

CX1648X SCHEMATIC DIAGRAM

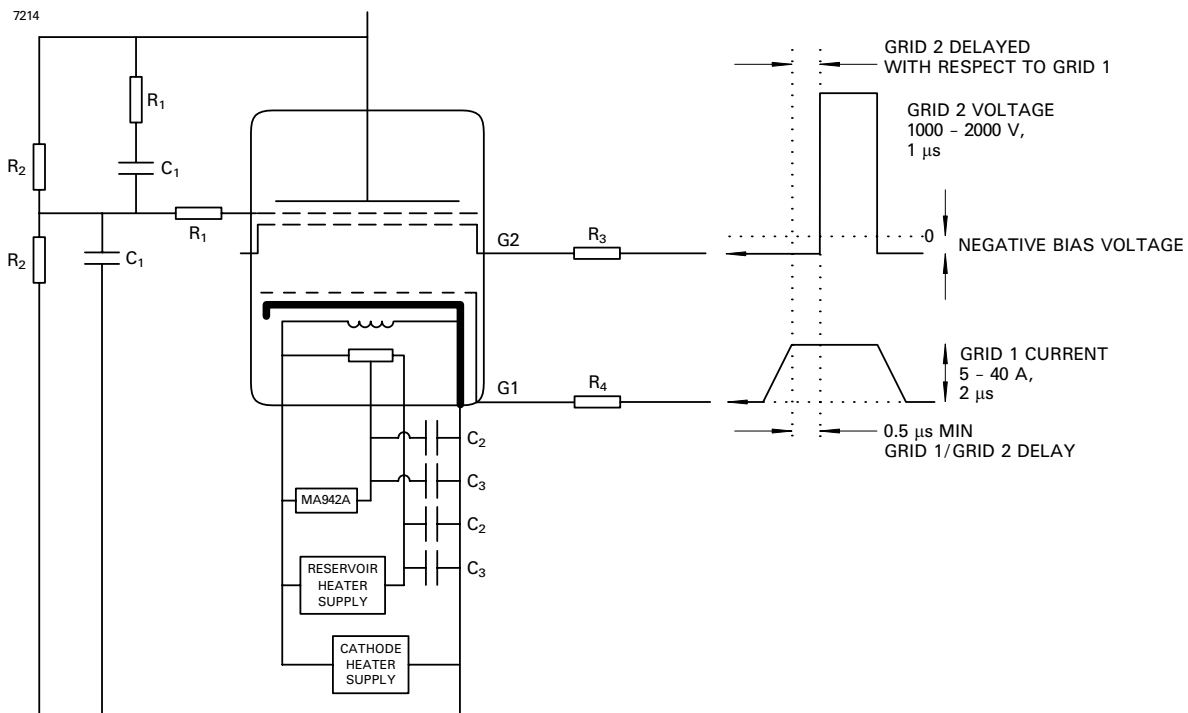

Recommended Values (both diagrams)

- R_1 = 470 Ω 2.5 W vitreous enamelled wirewound resistors.
- R_2 = 5 to 20 M Ω high voltage resistors with a power rating consistent with forward anode voltage.
- R_3 = Grid 2 series resistor. 12 W vitreous enamelled wirewound is recommended, of an impedance to match the grid 2 drive pulse circuit.
- R_4 = Grid 1 series resistor. 12 W vitreous enamelled wirewound is recommended, of a total impedance to match the grid 1 drive pulse circuit.

C_1 = 500 pF capacitors with a voltage rating equal to the peak forward voltage (C_1 is needed to share the anode voltage equally between the high voltage gaps on fast charging rates. When the charging time is greater than approx. 5 ms, C_1 may be omitted).

C_2, C_3 : Reservoir protection capacitors with a voltage rating ≥ 500 V;

C_2 = 1000 pF low inductance (e.g. ceramic),

C_3 = 1 μ F (e.g. polycarbonate or polypropylene).

Components R_3, R_4, C_2 and C_3 should be mounted as close to the tube as possible.

OUTLINE OF CX1648X (All dimensions without limits are nominal)

CX1648 outline is identical, except that it has no gas pressure control lead (black).

ANODE CONNECTION FITTED WITH
5 SCREWS 1/4-20 UNC, 1 IN CENTRE,
4 EQUISPACED ON G PCD

4515E

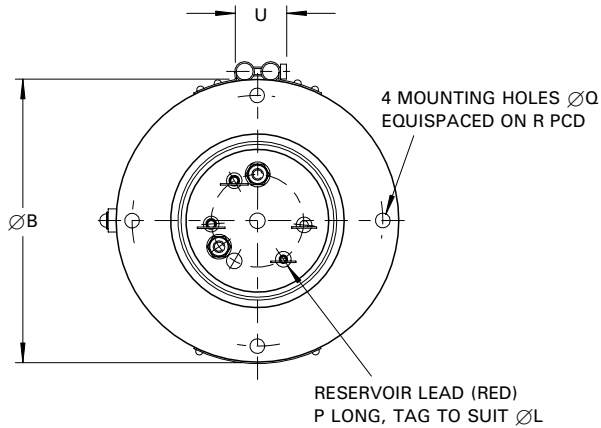
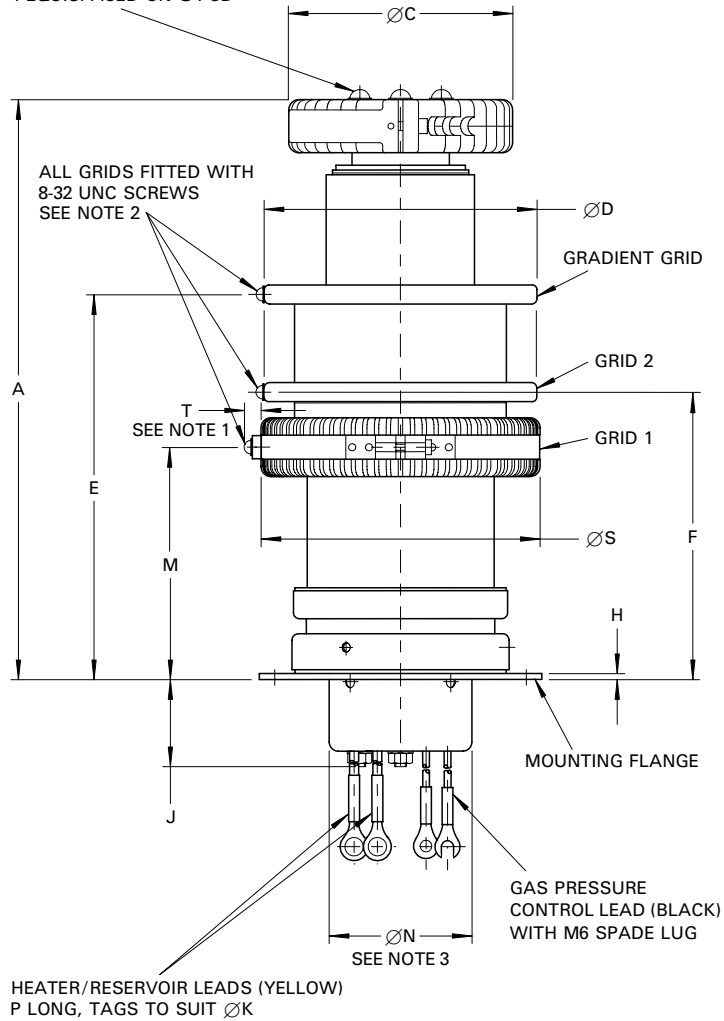

Ref	Millimetres	Inches
A	320.0 ± 6.0	12.598 ± 0.236
B	152.4 ± 0.25	6.000 ± 0.010
C	120.65 max	4.750 max
D	147.0 ± 3.0	5.787 ± 0.118
E	215.0 ± 6.0	8.465 ± 0.236
F	152.0 ± 6.0	5.984 ± 0.236
G	44.0	1.732
H	3.15 ± 0.35	0.124 ± 0.014
J	60.0 max	2.362 max
K	9.5	0.374
L	6.0	0.236
M	122.0 ± 6.0	4.803 ± 0.236
N	78.0 max	3.071 max
P	343.00 ± 6.35	13.504 ± 0.250
Q	8.0	0.315
R	135.7	5.343
S	152.4 ± 3.0	6.000 ± 0.118
T	15.0 max	0.591 max
U	36.0 max	1.417 max

Inch dimensions have been derived from millimetres.

Outline Notes

1. This dimension also applies to the clamping screws and lugs.
2. The terminal screws are in line with the hole in the mounting flange to within ±6.35 mm (0.250 inch).
3. The recommended mounting hole is 93.5 mm (3.861 inches) diameter.

MA942A RESISTOR BOX

'X' type thyratrons have an additional lead on the base which enables the user to adjust the gas pressure inside the tube to a greater degree than is possible by changing the reservoir voltage. This allows the gas pressure to be optimised for a particular set of operating conditions, reducing the power dissipation in the thyatron to a minimum and maximising its switching speed. The maximum gas pressure allowable is dependent on the voltage hold off required; the higher the gas pressure, the more likely the thyatron is to break down spontaneously. Optimisation is achieved by increasing the gas pressure until the thyatron will no longer reliably hold off the required anode voltage, and then reducing it again only until the tube will operate reliably without spontaneous anode voltage breakdowns.

The gas pressure of E2V Technologies metal envelope thyratrons is normally set during manufacture to allow reliable operation at the maximum rated anode voltage, by resistors inside the base cap of the tube. In 'X' type tubes, these resistors are omitted and replaced by two parallel variable resistors mounted in the MA942A resistor box which is connected to the thyatron as shown in the schematic diagram. Increasing the value of this parallel combination will increase the pressure in the thyatron.

'X' type thyratrons are supplied with a recommended minimum combination of values. Do not use a lower combined value of resistors as this would result in the tube being operated with an unacceptably low gas pressure and may lead to tube damage and reduced tube life.

Ten resistor values can be selected by each rotary switch (3.3 Ω , 4.7 Ω , 6.8 Ω , 8.2 Ω , 10 Ω , 15 Ω , 18 Ω , 22 Ω , 33 Ω , O/C), giving the range of possible values shown in the table.

Paralleled Value (Ω)	Control Box Settings (Ω)		Paralleled Value (Ω)	Control Box Settings (Ω)	
1.65	3.3	3.3	5.19	6.8	22.0
1.94	3.3	4.7	5.30	8.2	15.0
2.22	3.3	6.8	5.63	8.2	18.0
2.35	4.7	4.7	5.64	6.8	33.0
2.35	3.3	8.2	5.97	8.2	22.0
2.48	3.3	10.0	6.00	10.0	15.0
2.70	3.3	15.0	6.43	10.0	18.0
2.78	4.7	6.8	6.57	8.2	33.0
2.79	3.3	18.0	see note	6.8	O/C
2.87	3.3	22.0	6.87	10.0	22.0
2.99	4.7	8.2	7.50	15.0	15.0
3.00	3.3	33.0	7.67	10.0	33.0
3.20	4.7	10.0	8.18	15.0	18.0
see note	3.3	O/C	see note	8.2	O/C
3.40	6.8	6.8	8.92	15.0	22.0
3.58	4.7	15.0	9.00	18.0	18.0
3.72	6.8	8.2	9.90	18.0	22.0
3.73	4.7	18.0	see note	10.0	O/C
3.87	4.7	22.0	10.31	15.0	33.0
4.05	6.8	10.0	11.0	22.0	22.0
4.10	8.2	8.2	11.65	18.0	33.0
4.11	4.7	33.0	13.2	22.0	33.0
4.51	8.2	10.0	15.0	15.0	O/C
4.68	6.8	15.0	16.5	33.0	33.0
see note	4.7	O/C	18.0	18.0	O/C
4.94	6.8	18.0	22.0	22.0	O/C
5.00	10.0	10.0	33.0	33.0	O/C
			O/C	O/C	O/C

Note Do not set parallel resistors to these values, as this may cause the power rating of the resistor to be exceeded.

OUTLINE

(All dimensions without limits are nominal)

Ref	Millimetres	Inches
AA	125.0	4.921
AB	80.0	3.150
AC	57.0	2.244
AD	85.0 max	3.346 max

Inch dimensions have been derived from millimetres.

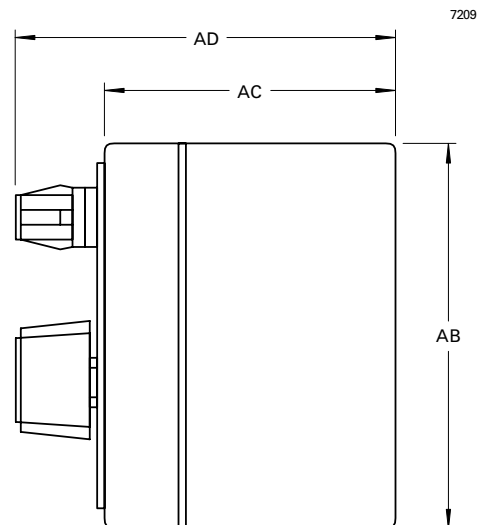
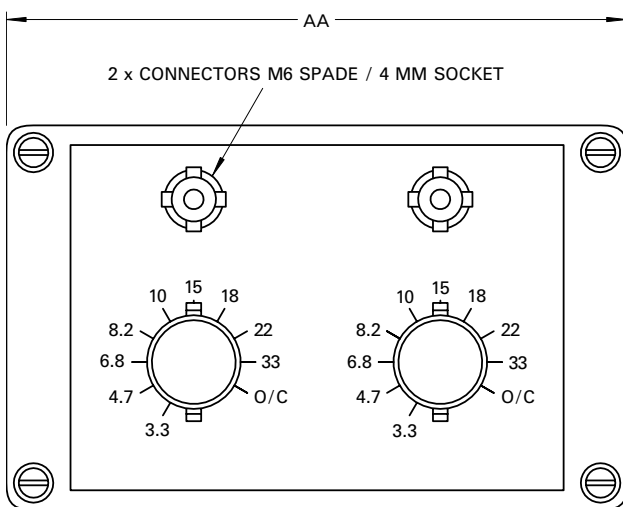

Whilst E2V Technologies has taken care to ensure the accuracy of the information contained herein it accepts no responsibility for the consequences of any use thereof and also reserves the right to change the specification of goods without notice. E2V Technologies accepts no liability beyond that set out in its standard conditions of sale in respect of infringement of third party patents arising from the use of tubes or other devices in accordance with information contained herein.