

The data to be read in conjunction with the Hydrogen Thyatron Preamble.

ABRIDGED DATA

Deuterium-filled two-gap thyratrons with metal/ceramic envelopes suitable for switching high peak and average power at high pulse repetition rates.

To optimise the switching performance, these thyratrons have been designed to be primed by a high current pre-pulse into grid 1. The use of a DC current to prime grid 1 may cause high values of time jitter.

A reservoir normally operated from a separate heater supply is incorporated. The reservoir heater voltage can be adjusted to a value consistent with anode voltage hold-off in order to achieve the fastest rate of rise of current possible from the tube in the circuit.

CX1525AX and CX1525AWX, which must be used in conjunction with e2v technologies resistor box MA942A, permit a larger variation in internal deuterium pressure than CX1525A and CX1525AW. Resistor box settings and/or reservoir heater voltage can be adjusted within the specified limits to obtain the maximum thyatron gas pressure consistent with the required voltage hold-off.

CX1525AW or CX1525AWX are required if coulombs per shot exceed 0.02 C.

Peak forward anode voltage	50	kV max
Peak anode current	5000	A max
Average anode current	5.0	A max
Operating frequency	25	kHz max

GENERAL DATA

Electrical

Cathode	barium aluminate impregnated tungsten	
Cathode heater voltage (see note 1)	6.3 ± 0.3	V
Cathode heater current	37.5	A
Reservoir heater voltage (see notes 1 and 2)	6.3 + 0.7 - 0.3	V
Reservoir heater current	7.0	A
Tube heating time (minimum)	10.0	min

Mechanical

Seated height	240 mm (9.449 inches) max
Clearance required below mounting flange	80 mm (3.150 inches) min
Overall diameter (excluding connections)	122 mm (4.803 inches) max
Net weight	3.6 kg (8 pounds) approx
Mounting position	see note 3
Tube connections	see outline

Cooling

The tube must be cooled by forced-air directed mainly onto the base and the metal/ceramic envelope should be maintained below the maximum rated temperature. A fan of output between 2.83 and 7.01 m³/min (100 and 250 ft³/min)

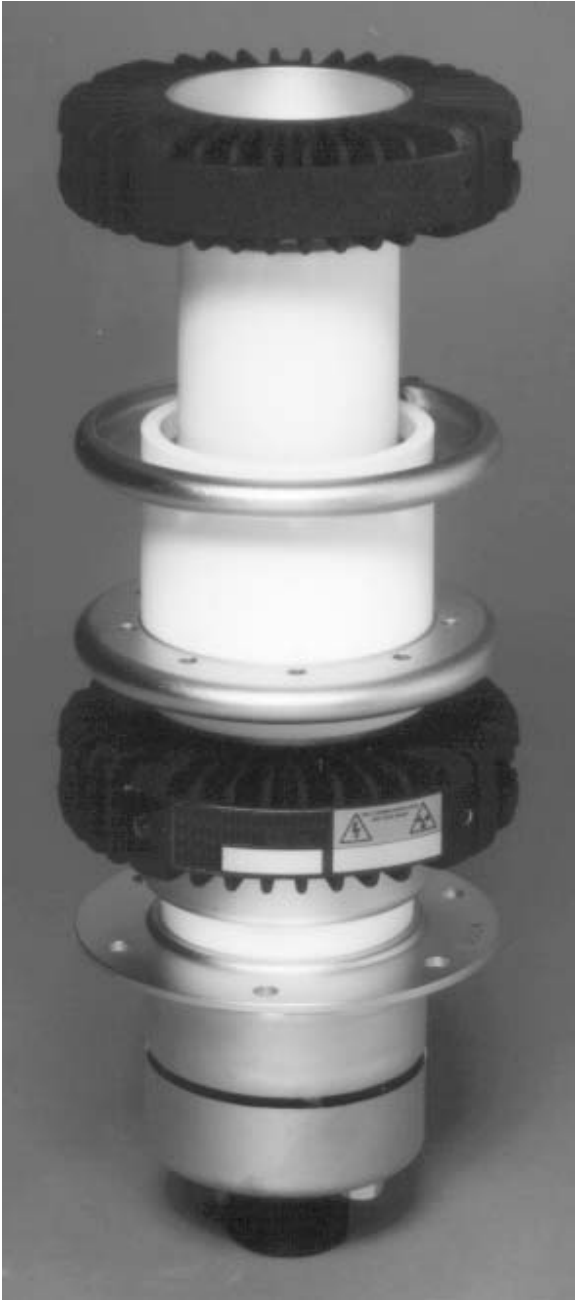

(depending on the mechanical layout) will be necessary to keep the tube operating temperatures below the limits specified below. e2v technologies cooling modules, types MA2235A and MA2235B, are suitable for the purpose.

In addition to 275 W of heater power, the tube dissipates from 100 watts per ampere average anode current, rising to 300 W/A or greater at the highest rate of rise and fall of anode current.

The cathode end of the tube must be cooled whenever heater voltages are applied.

Envelope temperature:	
anode, gradient grid, grid 1 and grid 2	200 °C max
cathode flange and end cover	120 °C max

e2v technologies (uk) limited, Waterhouse Lane, Chelmsford, Essex CM1 2QU, UK Telephone: +44 (0)1245 493493 Facsimile: +44 (0)1245 492492
e-mail: enquires@e2v.com Internet: www.e2v.com Holding Company: e2v technologies plc

e2v technologies inc. 4 Westchester Plaza, PO Box 1482, Elmsford, NY10523-1482 USA Telephone: (914) 592-6050 Facsimile: (914) 592-5148
e-mail: enquires@e2vtechnologies-na.com

PULSE MODULATOR SERVICE

MAXIMUM AND MINIMUM RATINGS

These ratings cannot necessarily be used simultaneously, and no individual rating must be exceeded.

	Min	Max	
Anode			
Peak forward anode voltage (see note 4)	-	50	kV
Peak inverse anode voltage		see note 5	
Peak forward anode current	-	5	kA
Average anode current	-	5	A
Rate of rise of anode current		see notes 6 and 7	
Coulombs per shot for CX1525A, AX	-	0.02	C

Triggering

These thyratrons should be triggered with a pre-pulse on grid 1.

	Min	Max	
Grid 2			
Unloaded grid 2 drive pulse voltage (see note 8)	600	2000	V
Grid 2 pulse duration	0.5	-	µs
Rate of rise of grid 2 pulse (see notes 7 and 9)	10	-	kV/µs
Grid 2 pulse delay (see note 10)	0.5	3.0	µs
Peak inverse grid 2 voltage	-	450	V
Loaded grid 2 bias voltage (see note 11)	-100	-300	V
Impedance of grid 2 drive circuit (see note 12)	50	200	Ω

Grid 1 - Pulsed

Unloaded grid 1 drive pulse voltage	600	2000	V
Grid 1 pulse duration	2.0	-	µs
Rate of rise of grid 1 pulse	1.0	-	kV/µs
Peak inverse grid 1 voltage	-	450	V
Loaded grid 1 bias voltage		see note 13	
Peak grid 1 drive current (see note 14)	10.0	25.0	A

Cathode

Heater voltage	6.3 ± 0.3	V
Heating time	10	min

Reservoir

Heater voltage	6.3 + 0.7 - 0.3	V
Heating time	10	min

Environmental

Ambient temperature	0	+40	°C
---------------------	---	-----	----

CHARACTERISTICS

	Min	Typical	Max	
Critical DC anode voltage for conduction	-	0.5	2.0	kV
Anode delay time	-	200	250	ns
Anode delay time drift (see note 15)	-	15	25	ns
Time jitter (see note 16)	-	1.0	5.0	ns
Recovery time (see note 17)	-	20	-	µs
Cathode heater current (at 6.3 V)	30	37.5	45	A
Reservoir heater current (at 6.3 V)	6.0	7.0	8.0	A

NOTES

- It is recommended that the cathode heater and the reservoir heater are supplied from independent power supplies. **The common connection for these two supplies is the yellow sleeved lead, not the cathode flange.**

N.B. The tube will suffer irreversible damage if the cathode flange is connected as the common point.

The cathode heater supply must be connected between the cathode flange and the cathode heater lead (yellow sleeve), the reservoir heater supply must be connected between the cathode heater lead (yellow sleeve) and the reservoir heater lead (red sleeve), see Figs. 1 and 2. In order to meet the jitter specification, it may be necessary in some circumstances that the cathode heater be supplied from a DC source.

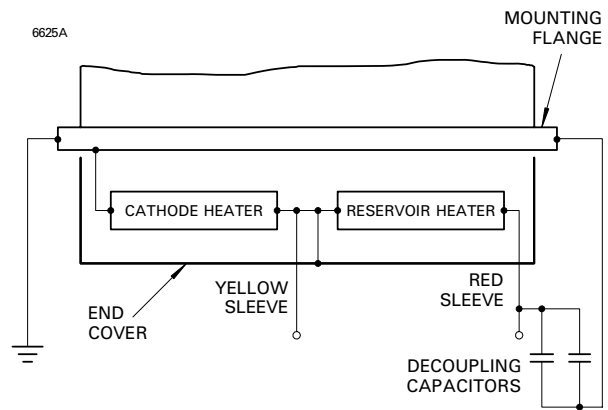

Fig. 1 CX1525A, CX1525AW base connections

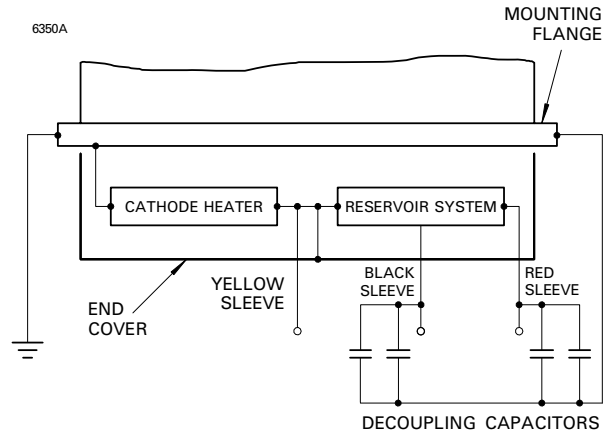

Fig. 2 CX1525AX, CX1525AWX base connections

Care should be taken to ensure that excessive voltages are not applied to the reservoir heater circuit from the cathode heater supply because of high impedance cathode heater connections. For example, in the worst case, an open circuit heater lead will impress almost double voltage on the reservoir heater, especially on switch-on, when the cathode heater impedance is minimal. This situation can be avoided by ensuring that the two supplies are in anti-phase. The reservoir heater circuit must be decoupled with suitable capacitors, for example, a 1 µF capacitor in parallel with a low inductance 1000 pF capacitor.

The heater supply systems should be connected directly between the cathode flange and the heater leads. This avoids the possibility of injecting voltages into the cathode and reservoir heaters. At high rates of rise of anode current, the cathode potential may rise significantly at the beginning of the pulse, depending on the cathode lead inductance, which must be minimised at all times.

If a single transformer is used to supply both the cathode heater and the reservoir heater, then the reservoir heater lead (red sleeve) must be connected to the mounting flange.

2. CX1525AX and CX1525AWX gas pressure may be altered using e2v technologies resistor box type MA942A. CX1525AX and CX1525AWX **must** be used in conjunction with the MA942A. The resistor box must be connected between the gas pressure control lead (black sleeve) and the cathode heater lead (yellow sleeve). Gas pressure may be increased by increasing the resistor box settings from their initial recommended values which accompany each delivered CX1525AX and CX1525AWX. The gas pressure may be increased to a value consistent with the required forward hold-off voltage. Additional variations in gas pressure can be achieved by altering the reservoir heater supply voltage within the specified range.
3. The tube must be fitted using its mounting flange, with flexible connections to all other electrodes. The preferred orientation is with the tube axis vertical and anode uppermost; mounting the tube with its axis horizontal is permissible. It is **not** recommended that the tube is mounted with its axis vertical and cathode uppermost.
4. The maximum permissible peak forward voltage for instantaneous starting is 40 kV and there must be no overshoot.
5. The peak inverse voltage including spike must not exceed 10 kV for the first 25 μs after the anode pulse. Amplitude and rate of rise of inverse voltage contribute greatly to the tube dissipation and electrode damage; if these are not minimised in the circuit, tube life will be shortened considerably. The aim should be for an inverse voltage of 3 – 5 kV peak with a rise time of 0.5 μs .
6. The ultimate value which can be attained depends to a large extent upon the external circuit. The rate of rise of current can be well in excess of 100 kA/ μs .
7. This rate of rise refers to that part of the leading edge of the pulse between 10% and 90% of the pulse amplitude.
8. Measured with respect to cathode.
9. A lower rate of rise may be used, but this may result in the anode delay time, delay time drift and jitter exceeding the limits quoted.
10. The last 0.25 μs of the top of the grid 1 pulse must overlap the corresponding first 0.25 μs of the top of the delayed grid 2 pulse.
11. Negative bias of 100 to 200 V must be applied to grid 2 to ensure anode voltage hold-off.

12. During both the drive pulse period and during recovery when the current flow is reversed.
13. DC negative bias voltages must not be applied to grid 1.
14. The optimum grid 1 pulse current is the maximum value which can be applied without causing the tube to switch before the grid 2 pulse is applied. This value is variable depending on gas pressure, maximum forward anode voltage, grid 2 negative bias voltage, peak current and repetition rate.
15. Measured between the second minute after the application of HT and 30 minutes later.
16. A time jitter of less than 1 ns can be obtained if the cathode heater voltage is supplied from a DC source, by adopting double-pulsing, and by applying a grid 2 pulse with a rate of rise of voltage (unloaded) in excess of 20 kV/ μs .
17. The amount of time available for thyatron recovery must be maximised by circuit design, and reliable operation may necessitate the use of command charging techniques. The amount of time required for recovery is affected by gas pressure, peak current, pulse duration and load mismatch which keeps the thyatron in a conducting state.

HEALTH AND SAFETY HAZARDS

e2v technologies hydrogen thyratrons are safe to handle and operate, provided that the relevant precautions stated herein are observed. e2v technologies does not accept responsibility for damage or injury resulting from the use of electronic devices it produces. Equipment manufacturers and users must ensure that adequate precautions are taken. Appropriate warning labels and notices must be provided on equipments incorporating e2v technologies devices and in operating manuals.



High Voltage

Equipment must be designed so that personnel cannot come into contact with high voltage circuits. All high voltage circuits and terminals must be enclosed and fail-safe interlock switches must be fitted to disconnect the primary power supply and discharge all high voltage capacitors and other stored charges before allowing access. Interlock switches must not be bypassed to allow operation with access doors open.



X-Ray Radiation

All high voltage devices produce X-rays during operation and may require shielding. The X-ray radiation from hydrogen thyratrons is usually reduced to a safe level by enclosing the equipment or shielding the thyatron with at least 1.6 mm ($1/16$ inch) thick steel panels.

Users and equipment manufacturers must check the radiation level under their maximum operating conditions.

OUTLINE OF CX1525A and CX1525AW

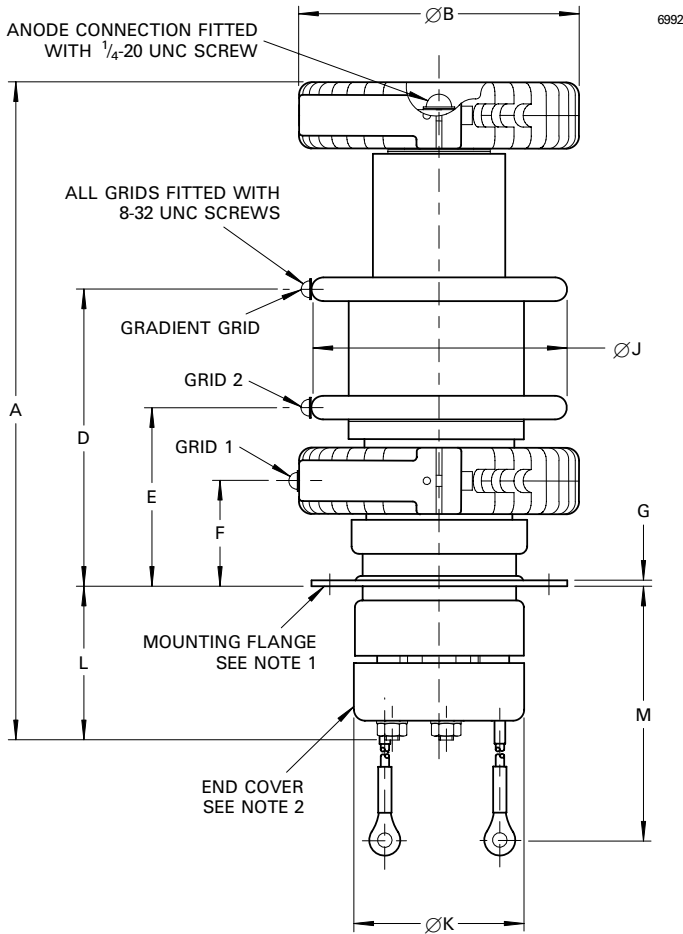

Outline Dimensions (all variants)

Ref	Millimetres	Inches
A	288.0	11.338
B	122.0 max	4.803 max
D	131.0	5.157
E	80.0	3.150
F	46.0	1.811
G	2.50	0.100
H	111.13	4.375
J	111.13	4.375
K	75.0 max	2.953 max
L	70.0 max	2.756 max
M	381.0	15.000
N	95.25	3.750
P	6.50	0.256

Inch dimensions have been derived from millimetres.

Outline Notes

1. The mounting flange is the connection for the cathode and cathode heater return.
2. The end cover is at heater potential and must not be grounded.

Detail of Mounting Flange

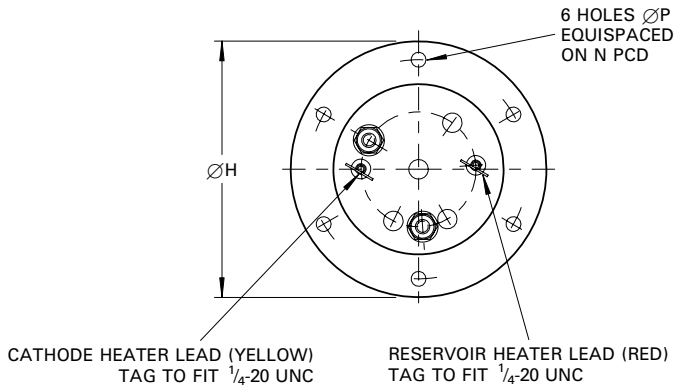

OUTLINE OF CX1525AX and CX1525AWX

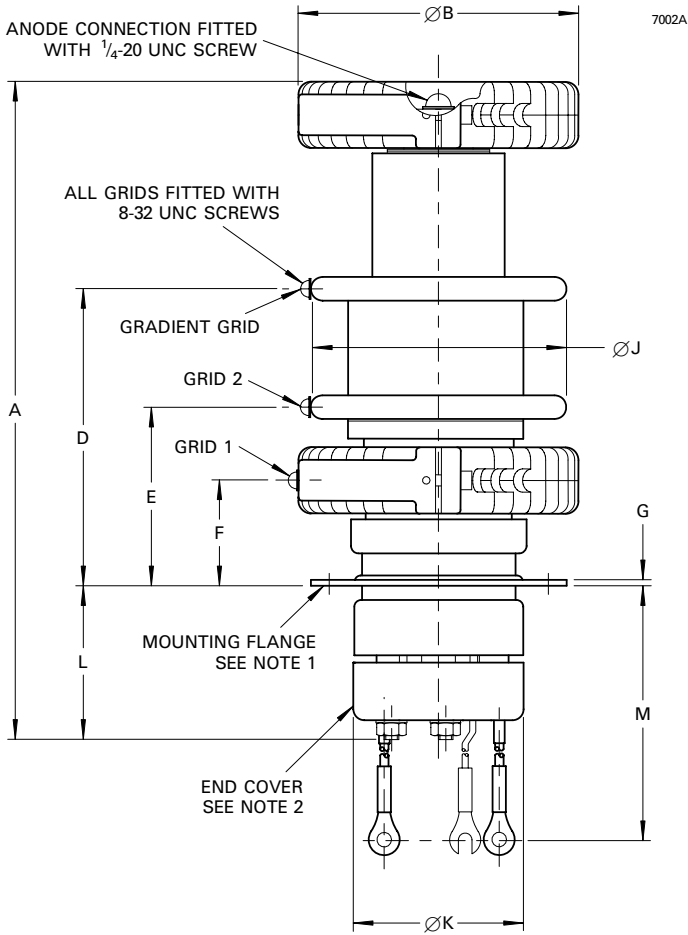

Detail of Mounting Flange

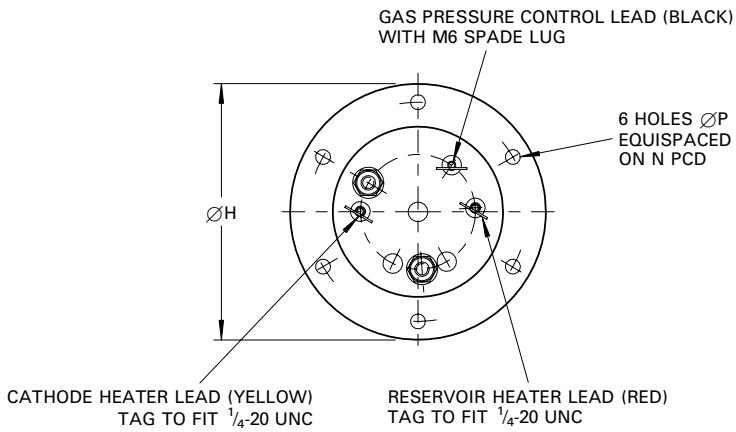

CX1525A, CX1525AW SCHEMATIC DIAGRAM

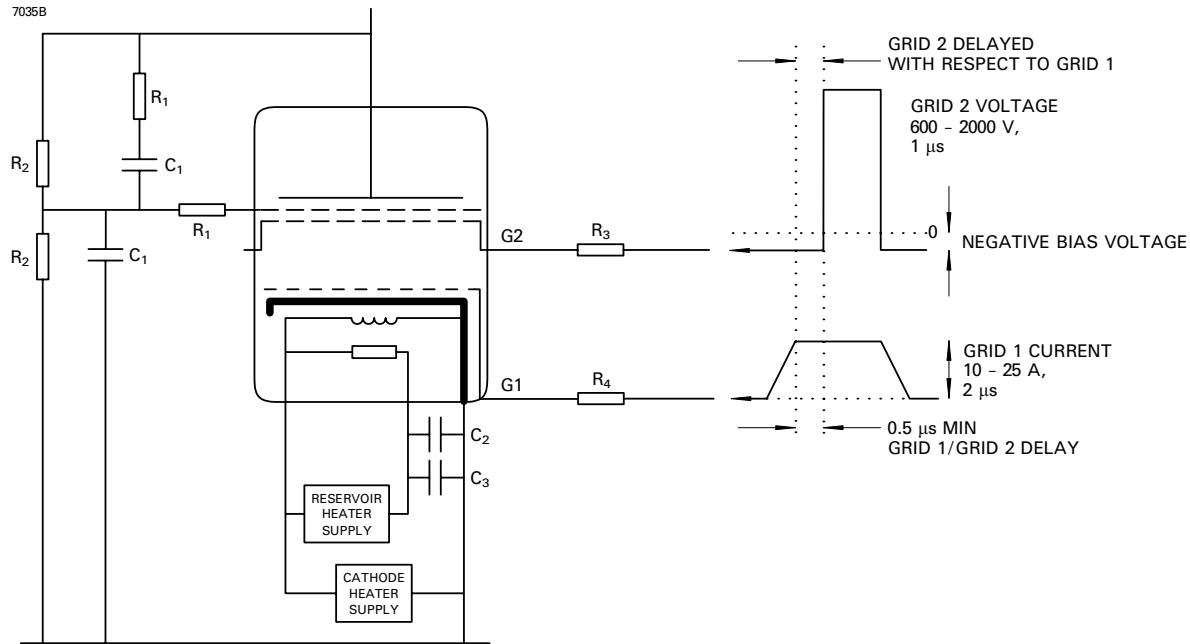

CX1525AX, CX1525AWX SCHEMATIC DIAGRAM

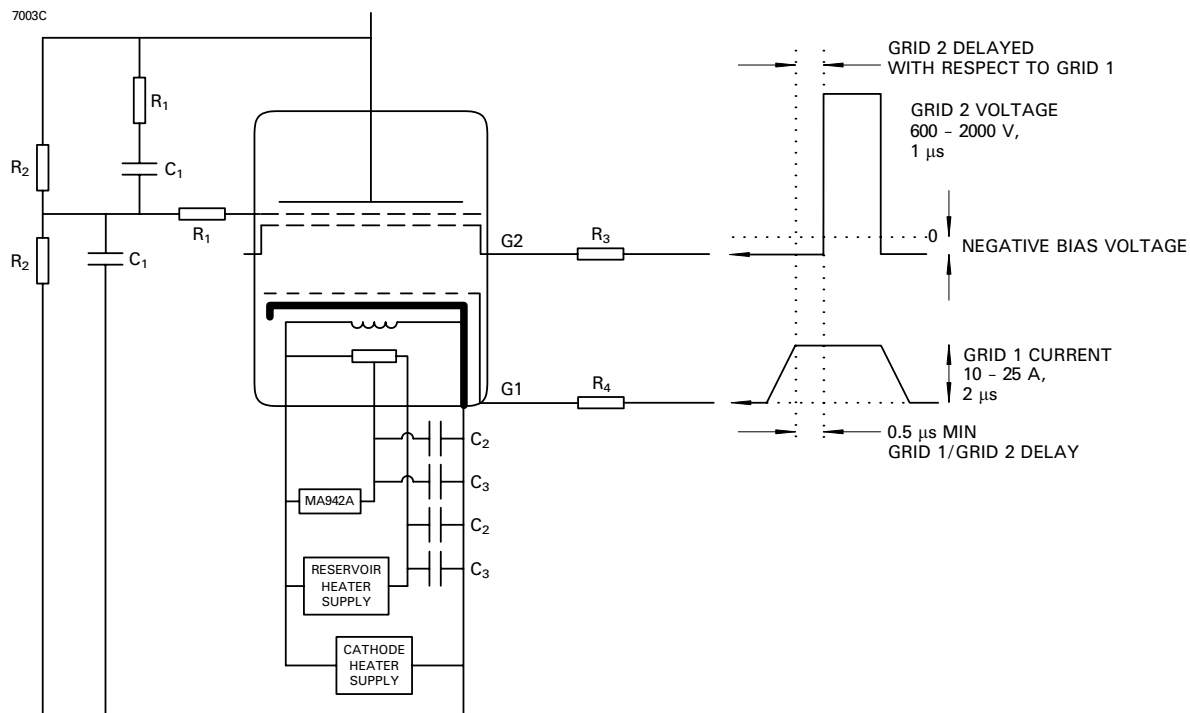

Recommended Values (both diagrams)

- R_1 = 470 Ω 2.5 W vitreous enamelled wirewound resistors.
- R_2 = 5 to 20 M Ω high voltage resistors with a power rating consistent with forward anode voltage.
- R_3 = Grid 2 series resistor. 12 W vitreous enamelled wirewound is recommended, of an impedance to match the grid 2 drive pulse circuit.
- R_4 = Grid 1 series resistor. 12 W vitreous enamelled wirewound is recommended, of a total impedance to match the grid 1 drive pulse circuit.

- C_1 = 500 pF capacitors with a voltage rating equal to the peak forward voltage (C_1 is needed to share the anode voltage equally between the high voltage gaps on fast charging rates. When the charging time is greater than approx. 5 ms, C_1 may be omitted).
 - C_2, C_3 : Reservoir protection capacitors with a voltage rating ≥ 500 V;
 - C_2 = 1000 pF low inductance (e.g. ceramic),
 - C_3 = 1 μ F (e.g. polycarbonate or polypropylene).
- Components R_3, R_4, C_2 and C_3 should be mounted as close to the tube as possible.

MA942A RESISTOR BOX

'X' type thyratrons have an additional lead on the base which enables the user to adjust the gas pressure inside the tube to a greater degree than is possible by changing the reservoir voltage. This allows the gas pressure to be optimised for a particular set of operating conditions, reducing the power dissipation in the thyatron to a minimum and maximising its switching speed. The maximum gas pressure allowable is dependent on the voltage hold off required; the higher the gas pressure, the more likely the thyatron is to break down spontaneously. Optimisation is achieved by increasing the gas pressure until the thyatron will no longer reliably hold off the required anode voltage, and then reducing it again only until the tube will operate reliably without spontaneous anode voltage breakdowns.

The gas pressure of e2v technologies metal envelope thyratrons is normally set during manufacture to allow reliable operation at the maximum rated anode voltage, by resistors inside the base cap of the tube. In 'X' type tubes, these resistors are omitted and replaced by two parallel variable resistors mounted in the MA942A resistor box which is connected to the thyatron as shown in the schematic diagram. Increasing the value of this parallel combination will increase the pressure in the thyatron.

'X' type thyratrons are supplied with a recommended minimum combination of values. Do not use a lower combined value of resistors as this would result in the tube being operated with an unacceptably low gas pressure and may lead to tube damage and reduced tube life.

Ten resistor values can be selected by each rotary switch (3.3 Ω , 4.7 Ω , 6.8 Ω , 8.2 Ω , 10 Ω , 15 Ω , 18 Ω , 22 Ω , 33 Ω , O/C), giving the range of possible values shown in the table.

OUTLINE

(All dimensions without limits are nominal)

Ref	Millimetres	Inches
AA	125.0	4.921
AB	80.0	3.150
AC	57.0	2.244
AD	85.0 max	3.346 max

Inch dimensions have been derived from millimetres.

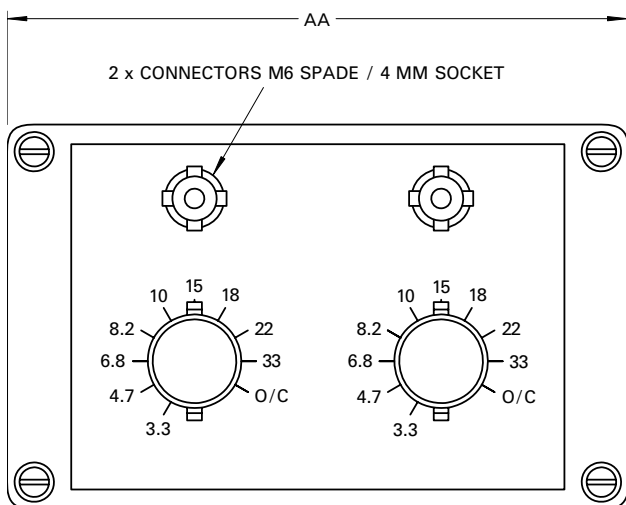

Paralleled Value (Ω)	Control Box Settings (Ω)		Paralleled Value (Ω)	Control Box Settings (Ω)	
1.65	3.3	3.3	5.19	6.8	22.0
1.94	3.3	4.7	5.30	8.2	15.0
2.22	3.3	6.8	5.63	8.2	18.0
2.35	4.7	4.7	5.64	6.8	33.0
2.35	3.3	8.2	5.97	8.2	22.0
2.48	3.3	10.0	6.00	10.0	15.0
2.70	3.3	15.0	6.43	10.0	18.0
2.78	4.7	6.8	6.57	8.2	33.0
2.79	3.3	18.0	see note	6.8	O/C
2.87	3.3	22.0	6.87	10.0	22.0
2.99	4.7	8.2	7.50	15.0	15.0
3.00	3.3	33.0	7.67	10.0	33.0
3.20	4.7	10.0	8.18	15.0	18.0
see note	3.3	O/C	see note	8.2	O/C
3.40	6.8	6.8	8.92	15.0	22.0
3.58	4.7	15.0	9.00	18.0	18.0
3.72	6.8	8.2	9.90	18.0	22.0
3.73	4.7	18.0	see note	10.0	O/C
3.87	4.7	22.0	10.31	15.0	33.0
4.05	6.8	10.0	11.0	22.0	22.0
4.10	8.2	8.2	11.65	18.0	33.0
4.11	4.7	33.0	13.2	22.0	33.0
4.51	8.2	10.0	15.0	15.0	O/C
4.68	6.8	15.0	16.5	33.0	33.0
see note	4.7	O/C	18.0	18.0	O/C
4.94	6.8	18.0	22.0	22.0	O/C
5.00	10.0	10.0	33.0	33.0	O/C
			O/C	O/C	O/C

Note Do not set parallel resistors to these values, as this may cause the power rating of the resistor to be exceeded.

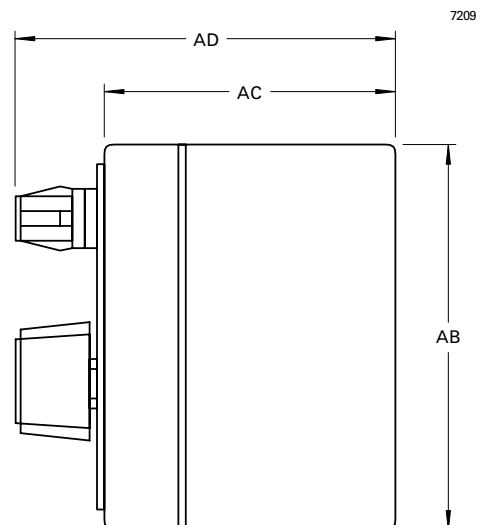

MA2235A/MA2235B COOLING MODULES

The MA2235A/MA2235B cooling modules are designed to air-cool the e2v technologies range of medium size metal envelope thyratrons. The MA2235A is fitted with a 110 V 40 W fan and the MA2235B with a 220 V 40 W fan.

The cooling system consists of a thyatron mounting flange assembly, grid connectors, upper and lower plastic air ducts, and a fan. To prevent the thyatron overheating, a fan stop detection device (see Fig. 3) is fitted to the finger guard below the fan. This is a heated thermal reed switch consuming approximately 7 W at the same mains power supply voltage as the cooling fan. The reed switch contacts open shortly after fan failure and must be connected to the system so that all power (high voltage and thyatron heater supplies) is removed from the thyatron in the event of air flow reduction or stoppage.

Nominal mains power supply voltage:

MA2235A	110	V ac
MA2235B	220	V ac
Ambient temperature	0 to 60	°C
Weight	3.6	kg

Maximum electrical contact ratings for reed switch (terminals 1 and 2):

	AC	DC	
Voltage	140	200	V
Current	0.5	0.5	A
Power	35	10	W

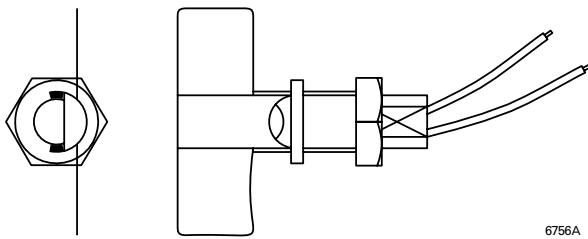
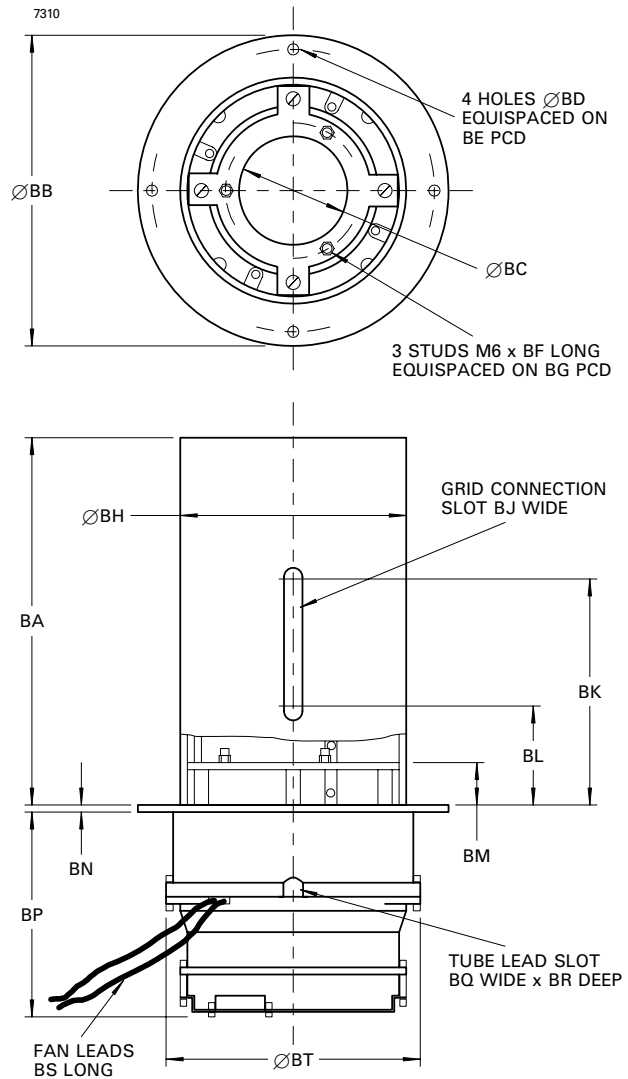

Fig. 3. Fan stop detection device

OUTLINE

(All dimensions without limits are nominal)



Ref	Millimetres	Inches
BA	260.0	10.236
BB	220.0	8.661
BC	76.2	3.000
BD	7.0	0.276
BE	200.0	7.874
BF	13.0	0.512
BG	95.25	3.750
BH	160.0	6.299
BJ	12.7	0.500
BK	164.0	64.57
BL	70.0	2.756
BM	28.6	1.126
BN	4.75	0.187
BP	145.0 max	5.709 max
BQ	16.0	0.630
BR	16.0	0.630
BS	254.0 min	10.000 min
BT	181.0 max	7.126 max

Inch dimensions have been derived from millimetres.

Whilst e2v technologies has taken care to ensure the accuracy of the information contained herein it accepts no responsibility for the consequences of any use thereof and also reserves the right to change the specification of goods without notice. e2v technologies accepts no liability beyond that set out in its standard conditions of sale in respect of infringement of third party patents arising from the use of tubes or other devices in accordance with information contained herein.