



# Powerstart 400

- Innovative in energy storage & Power Electronics
- Custom-made solutions
- Complete solution: storage & Power Electronics
- Design and system integration



## Features

- Cold temperature performance
- High efficiency: improves starting performance
- Low internal resistance, high peak current
- Long life cycle
- Integrated DC/DC converter
- Integrated Trickle converter
- Integrated individual cell balancing
- Compact, rugged, fully enclosed and IP65 design
- Extension battery life, downsizing main battery
- Clamping of external power relay for 15 seconds
- Built in overvoltage switch
- Approved for heavy-duty shock and vibration norms

## Mechanical Data

Length x Width x Height  
459 x 259 x 182 mm  
11 kg

## Applications

Diesel engine cranking & board net stabilization for

- (Cold Climate) transport
- Automotive
- Marine
- Industrial
- Railway

[aephybridpower.com](http://aephybridpower.com)  
[sales@aephybridpower.com](mailto:sales@aephybridpower.com)  
+31 (0)78 692 2100

## Overview

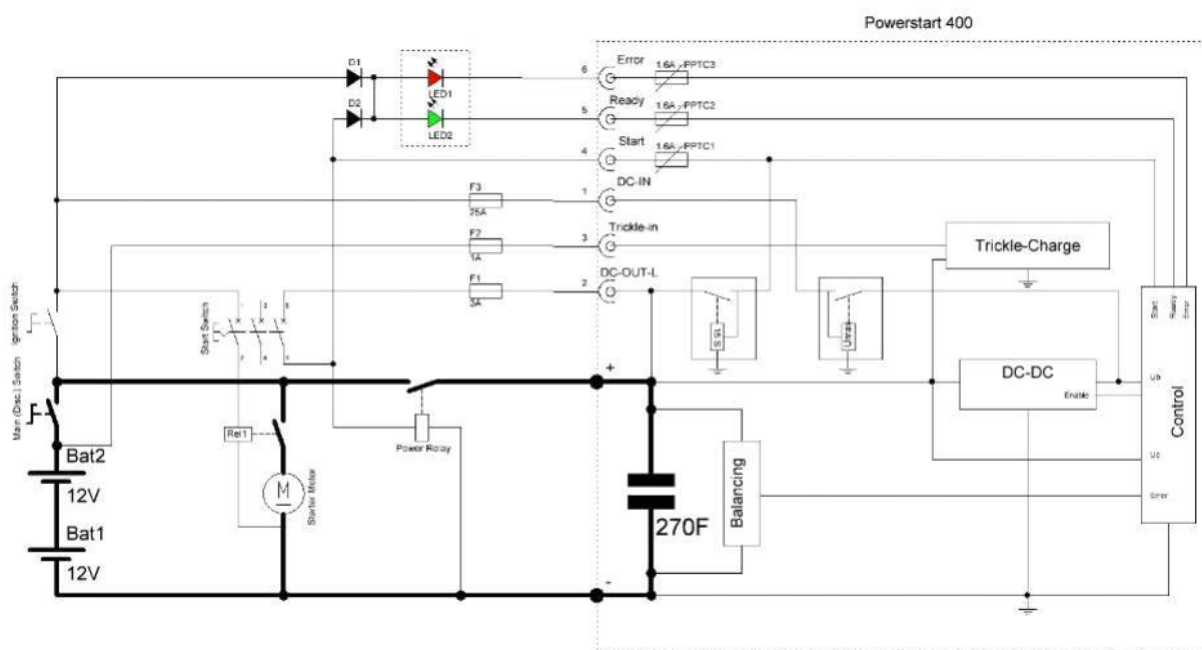

This block diagram is showing a typical (parallel) configuration. Configuration may vary per application. A dedicated start configuration is also possible.

## Global Specifications

Symbol	Parameter	Min.	Typ.	Max.	Units	Comment
T <sub>A</sub>	Ambient air temperature	-40	-	+60 <sup>1</sup>	°C	-
P	Peak power	-	-	50	kW	-
CCA	Max. cold crank amp.	-	-	2000	A <sub>rms</sub>	Power+ t < 1
U <sub>nom</sub>	Rated voltage	-	27.5	-	VDC	Power+ / DC-OUT-L
U <sub>TR</sub>	Transient peak voltage	-	-	150	VDC	Exponentially decreasing to 28V within 4 s
C	Capacity	-	270	-	F	(=100kJ @ 27.5VDC)
I <sub>L</sub>	Leakage current	-	5.5	-	mA	-
	Cycle life	1.000.000	-	-	Cycles	-
	Lifetime	-	10	15	Years	-
t	Time delay for external relay	-	15	-	s	Power+ / DC-OUT-L/Start
I <sub>CAP</sub>	Charge current	0.15	20 <sup>2</sup>	25	A <sub>rms</sub>	DC-IN
I <sub>tr</sub>	Trickle charge current	1	-	50	mA	Trickle-IN

<sup>1</sup> up to 50°C three recharges 18V to 27V possible. If T ≥ 60°C charge locked. A temperature over 65°C is critical!

<sup>2</sup> Reducing by temperature over 45°C permitted. Short transients t < 2 s are allowed.

## Mechanical Data

Length x Width x Height: 459 x 259 x 182 mm or 18 x 10 x 7 inch

Weight: Approx. 11 kg or 24 lbs

Enclosure: IP65

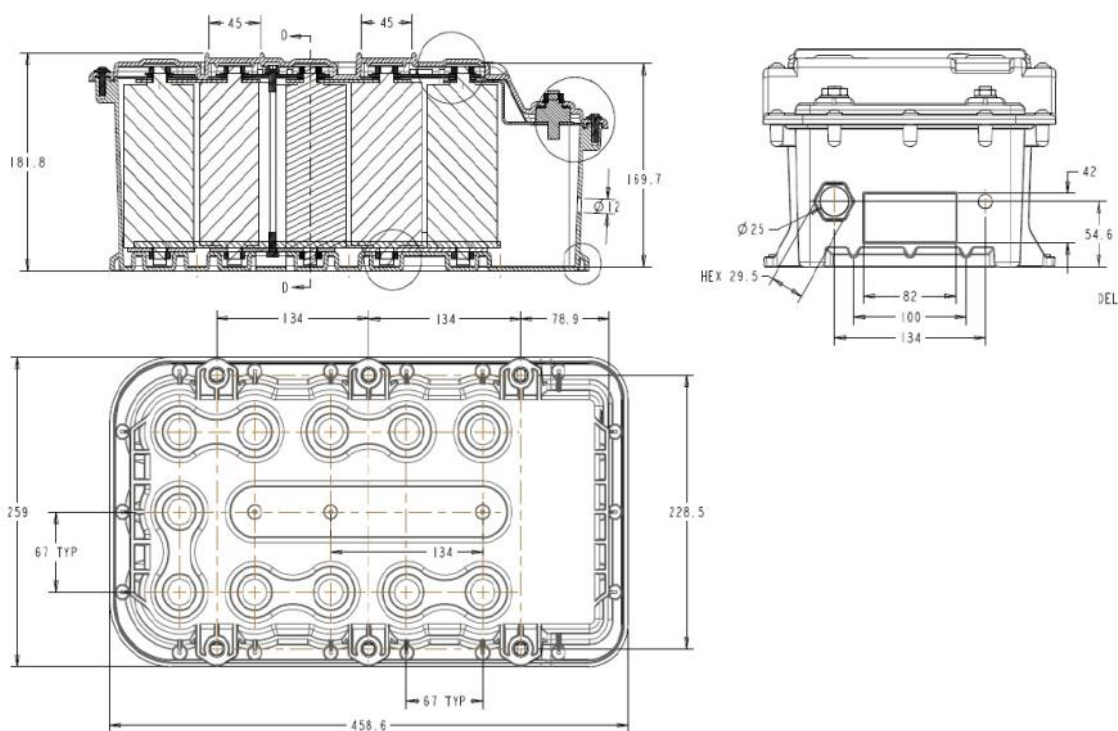

## Certifying Tests

Description / Conditions	
J1455 AUG2012	Shock and Vibration according to recommended environmental practices for Electronic Equipment Design in Heavy-Duty Vehicle Applications
72/245/EEC	Radio interference (electromagnetic compatibility) of vehicles