

FEATURES

- Configured for carbon dioxide (IR601), hydrocarbons (IR602, IR603) and acetylene (IR604)
- Sensing ranges 0 - 2% vol. (opt. 0 - 5% vol.) for CO₂, 0 - 100% LFL (opt. 0 - 100% vol.) for hydrocarbons
- Diffused gas sampling via sinter
- Low power
- Reference channel for self-compensation
- Special gold plated optical/gas cavity for stable signal levels
- Operational in varying ambients of temperature, pressure and humidity
- Fast response
- Rugged stainless steel construction
- No moving parts
- Resistance to corrosion
- Immunity from 'poisoning'
- Reliable fail-safe operation
- Low maintenance
- Sealed preamplifier/buffer electronics
- Compatible with SGX Sensortech TX600 circular transmitter board and DX600 display board
- Accessories available for field applications
- ATEX certified  II 2G Ex d IIC T5 Gb (T_a = -20 to +60 °C)
- CSA certified -- File 107498

DESCRIPTION

The IR600 Series are designed to detect and monitor the presence of CO₂, methane, broadband hydrocarbons and acetylene using the same non-dispersive infrared (NDIR) principle as used in the SGX Sensortech range of miniature infrared gas sensors. Dual detector channels are used with a reference for background compensation. A temperature sensor is mounted for temperature compensation.

The IR601 is filtered specifically for CO₂, whereas the IR602 and IR603 are cross-sensitive to a range of hydrocarbons. The IR603 covers the wider range but has a slight response to water vapour when the RH is high. The IR602 is filtered to a narrower waveband, more specific to methane and shows less response to the water levels typically found in mining applications. The IR604 is narrowly filtered for acetylene, but has some response to water due to the close proximity of the water absorption bands. For more information, refer to Infrared Sensor Application Note 1.

IR600 sensors are designed to be integrated with fixed gas detection systems. Their construction is a stainless steel flameproof enclosure with an integral stainless steel sinter for the safe entry of the gases being tested.

Three types of mounting thread are available to allow easy fixing to the junction box of the fixed system. On the front face there is an external M46 thread for attaching optional accessories for use in different applications. The three accessories available are: Flow Cap, Weather Cap and Quick Calibration Hood.



The IR600 Series incorporate an inbuilt and sealed preamplifier/buffer that must be coupled directly to a transmitter/display as typified by the SGX Sensortech TX600 circular transmitter and display boards. The IR600 lead in/out terminates in an 8-pin connector.

CERTIFICATIONS

The IR600 Series is certified by SIRA Certification Services, EU Notified Body No. 0518.

Certificate number BAS01ATEX2110X certifies it as flameproof equipment to EN60079-0:2006 (including amendments A1 and A2) and EN60079-1:2007 subject to the **Instructions specific to hazardous area installations**.

The IR600 Series is certified by CSA International for Class 1, Groups B, C and D hazardous locations for both Canada and the USA.

Certification for Canada is as products in Class 4818 03 to the requirements of CSA Standards C22.2 No. 30-M1986 and C22.2 No. 142-M1987 and is covered by File No. LR107498.

OPERATION

The NDIR operating principles are described in the following SGX Sensortech Infrared Sensor Application Notes, available from the SGX Sensortech website:

- Note 1: Background to NDIR Gas Sensing
- Note 2: Signal Processing
- Note 3: Software Design
- Note 4: Electronics Design
- Note 5: Determining Coefficients for Linearisation and Temperature Compensation
- Note 6: Advice for Using Infrared Gas Sensors in Mining Applications

Data sheets for the recommended transmitter and display are: A1A-TX600 and A1A-DX600.

HANDLING PRECAUTIONS

1. Do not allow sensors to fall on the floor. This could cause lamp filament breakage, damage to the pins and the gas entrance aperture.
2. Do not apply mechanical force against the gas entrance aperture.
3. Do not immerse sensors in water or other fluids.
4. Protect the gas entrance aperture against dust ingress and sprayed materials.
5. Anti-static handling precautions must be taken.

FRACTIONAL ABSORBANCE CURVES

These show the sensitivity versus concentration before linearisation for the range of gases. For further explanation, refer to the Infrared Sensor Application Notes.

Typical Sensitivity to 0 to 2% vol. Carbon Dioxide (IR601)

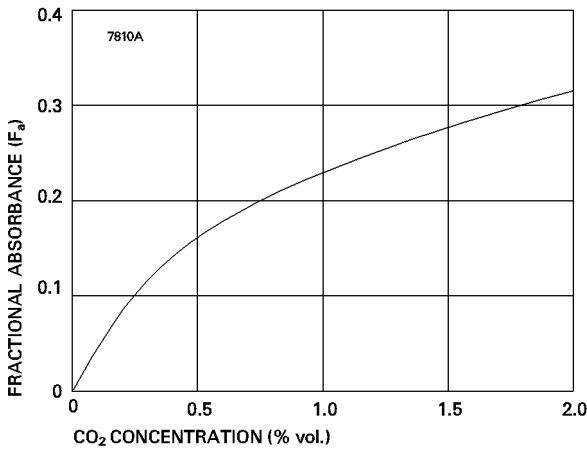

Typical Sensitivity to Methane (100% LFL = 5% vol) (IR603)

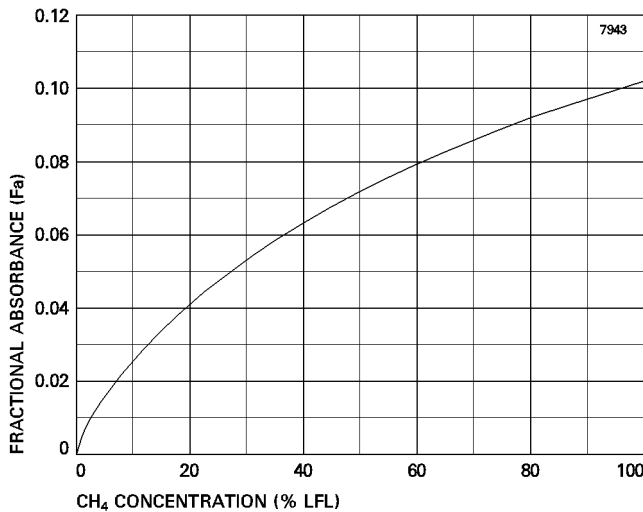

Typical Sensitivity to Methane (100% LFL = 5% vol) (IR602)

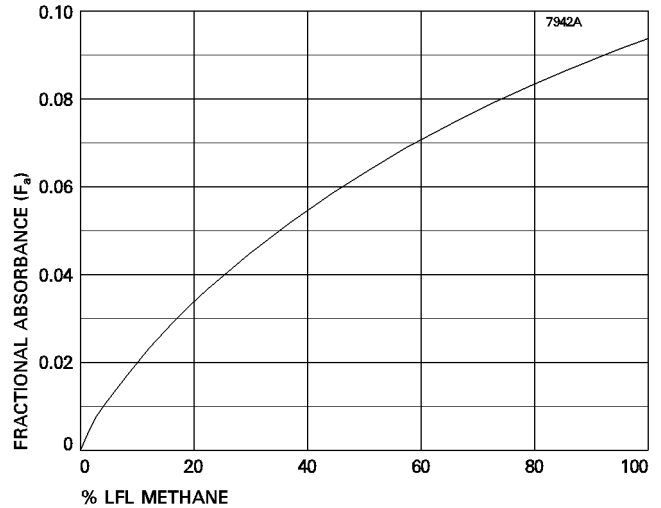

Typical Sensitivity to Ethylene (100% LFL = 3% vol.) (IR602, IR603)

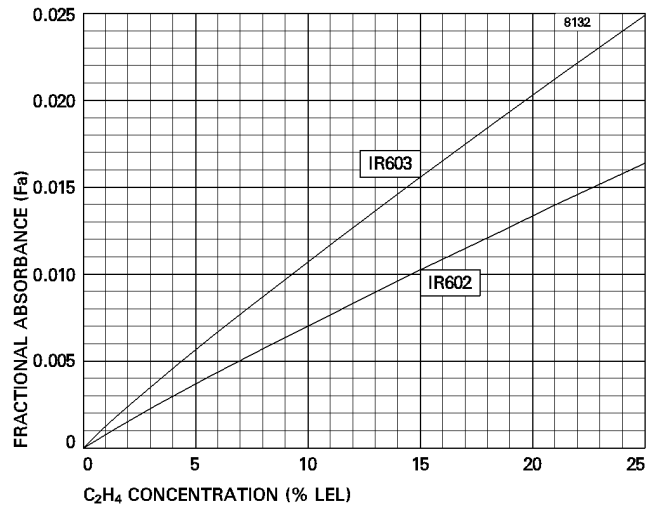

Typical Sensitivity to Propane (100% LFL = 2.4% vol.) (IR602, IR603)

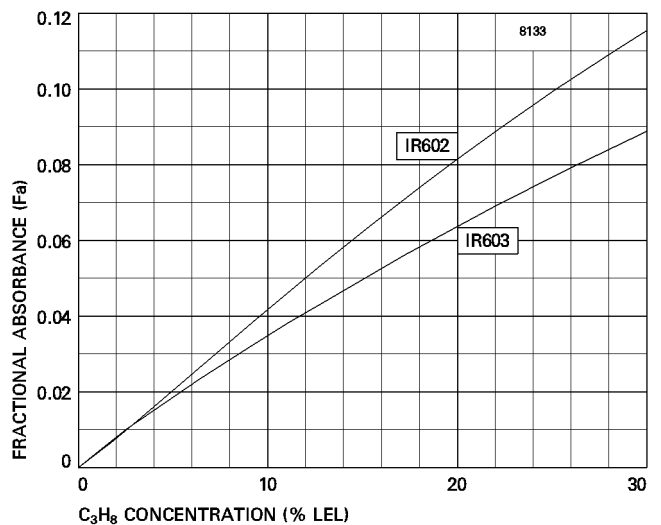

**Typical Sensitivity to Benzene
(100% LFL = 1.5% vol.) (IR603)**

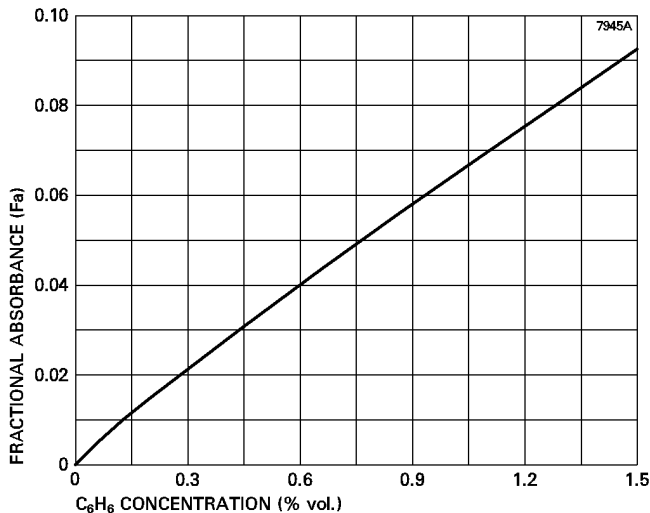

**Typical Sensitivity to Acetylene
(100% LFL = 2.5% vol.) (IR604)**

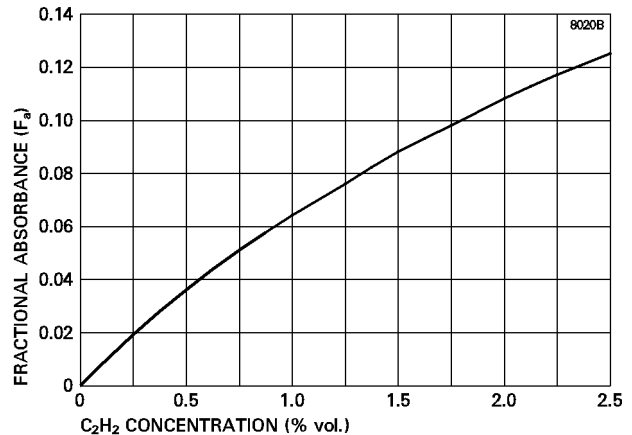

INSTRUCTIONS SPECIFIC TO HAZARDOUS AREA INSTALLATIONS

(Ref. EU ATEX Directive 94/9/EC, Annex II, 1.0.6)

1. The head is classified as flameproof equipment and is marked:

**BAS01ATEX2110X
II 2G Ex d IIC T5 Gb
T_a = -20 °C to +60 °C
2 W/5 V MAX**

The head should only be used within the limits imposed by this certification and by these conditions of use.

2. The head may be used in a hazardous area without further mechanical protection. However, the cable requires mechanical protection and must be terminated in a suitable enclosure.
3. The head must be efficiently earthed (grounded). This may be achieved by mounting it into an appropriate earthed metal junction box or into a non-metallic junction box fitted with an earth continuity plate used in accordance with the box manufacturer's instructions. There are no internal connections to the sensing head body.
4. In the event that the head becomes embedded in a junction box by over-tightening or corrosion, it may be released by the use of a spanner or wrench on the two flat surfaces on the sides of the body.
5. There are no user serviceable parts inside the body of the sensing head, and no attempt should be made to open the body for any purpose. The unit is non-repairable.
6. The head has not been assessed as a safety device (EHSR 1.5).
7. When installed in outdoor locations where rain or spray could interfere with the safe working of the head, or in indoor locations where water jets, sprays, or hoses are used routinely for cleaning purposes, the head should be fitted with the Weather Cap that is available as an accessory.
8. The end-user/installer should be aware that the certification of the head relies in its construction on the use of the following materials, which are suitable for most common applications:

Enclosure Stainless Steel
Sinter..... Stainless Steel
Bushing Epoxy resin

In accordance with the Note in EN60079-0:2006 Clause 6.1(a), the end-user/installer shall inform the manufacturer of any adverse conditions that the head may encounter. This is to ensure that the head is not subject to conditions that may cause degradation of these materials.

TECHNICAL SPECIFICATION

Mechanical

Dimensions	see outline, page 5
Body material	stainless steel
Weight	435 g

Environmental

Ambient temperature range: for operation for storage	-20 to +55 °C -20 to +60 °C
Operational pressure range	700 to 1300 hPa
Humidity range for operation and storage	0 to 95% non-condensing
Vibration	complies with EN61779-1
Ingress protection	see Weather Cap accessory, page 6

Electrical

Input/output connector wiring	see outline, page 5
Maximum power supply	180 mW
Lamp supply	+5 V max, 60 mA recommended Note: Applying >5 V will reduce the lamp lifetime

PERFORMANCE

Note: For test purposes, all data taken using TX600 transmitter with these conditions:

- SGX Sensortech linearisation and temperature compensation algorithms; see Infrared Sensor Application Notes.
- Lamp modulation 0.4 - 5.0 V, square wave, at 4 Hz and 50% duty cycle.
- Ambient temperature (20 °C) and pressure (1010 hPa).
- All gases diluted in nitrogen.

Sensor type	IR601	IR602	IR603	IR604
Gas	Carbon Dioxide	Hydrocarbons		Acetylene
Sensing range	0 - 3000 ppm 0 - 2.0% vol. 0 - 5.0%vol.	0 - 100% LFL 0 - 100% vol.		0 - 100% LFL 0 - 100% vol.
Maximum response time (T90)	<40 s			
Voltage output in nitrogen for active and reference channels	4.0 ± 0.5 V centred on 2.5 V			
Sensitivity to gas over full concentration range (before linearisation)	see Fractional Absorbance curves			
Maximum deviation from linearity	$\pm 0.1\%$ vol.			
Maximum variation of zero from -20 to +55 °C	± 10 ppm/°C	± 20 ppm/°C		
Resolution (dependent on electronics)	100 ppm	500 ppm		
Maximum non-reproducibility of zero at 20 °C	± 100 ppm	± 500 ppm		
Maximum non-reproducibility of sensitivity at 20 °C	± 200 ppm	< ± 1000 ppm		
Long-term zero drift/month	< ± 100 ppm	± 500 ppm		
Response to 0 - 90% change in RH at 20 °C (in target gas)	0% vol.	+0.1% vol.	+0.3% vol.	+0.5% vol.
MTBF (lamp dependent only)	>10 years for 5 V operation			

OUTLINE (All dimensions in millimetres; dimensions without limits are nominal)

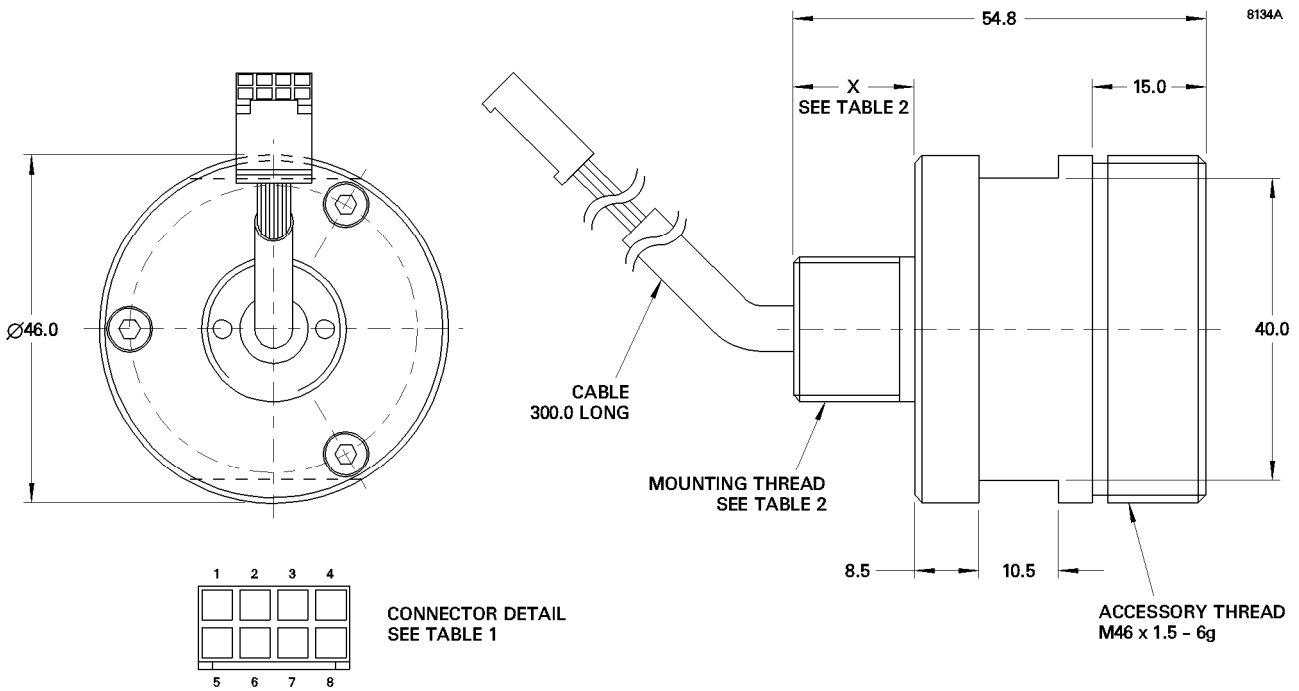

Table 1 - Connections

HE14 crimp socket, 8-way double-row, single orientation

Socket	Wire Colour	Description
1	Red	Temperature Output
2	Yellow	Active Detector Output
3	Blue	0 VA
4	Black	5 VA
5	Orange	2.5 V Reference
6	Brown	Reference Detector Output
7	Green	Lamp
8	Purple	Lamp

Table 2 - Mounting Options

The sensing head is supplied with one of three different mounting threads at the user's choice.

Thread	Thread code	Dimension X (mm)
Metric 20 x 1.5 mm	1	16.00
ANP (Taper) 1/2" - 14 NPT	2	19.85
ANP (Taper) 3/4" - 14 NPT	3	20.16

Taper threads are manufactured in accordance with ANSI/ASME B1.20.1.

ACCESSORIES

(All dimensions in millimetres)

Three accessories are available to complement the IR600 Series gas detection head. These accessories are shown on page 6, with the IR600 in place.

Flow Cap DAS546633AA

7847

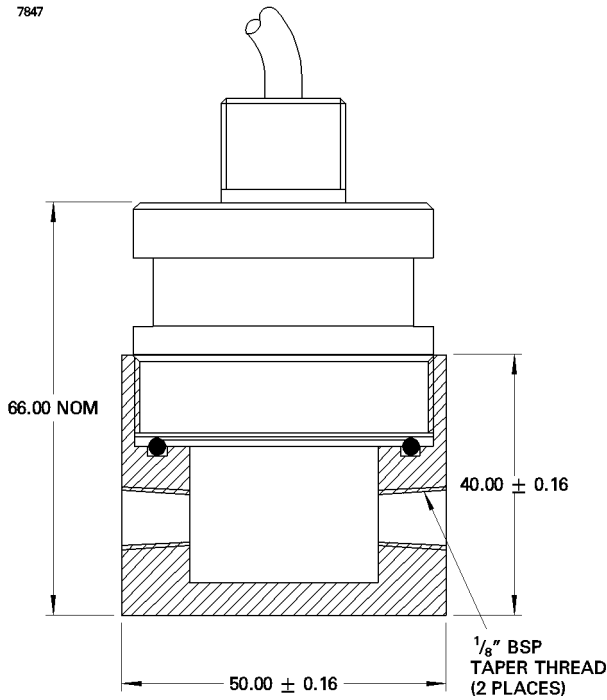

The Flow Cap allows the IR600 to be used in applications where it is to be aspirated permanently with a pumped or pressurised sample. The cap is made of 316 stainless steel and can be used in a variety of applications involving pumped sampling analysis or detection systems.

Weather Cap DAS546632AA

7848

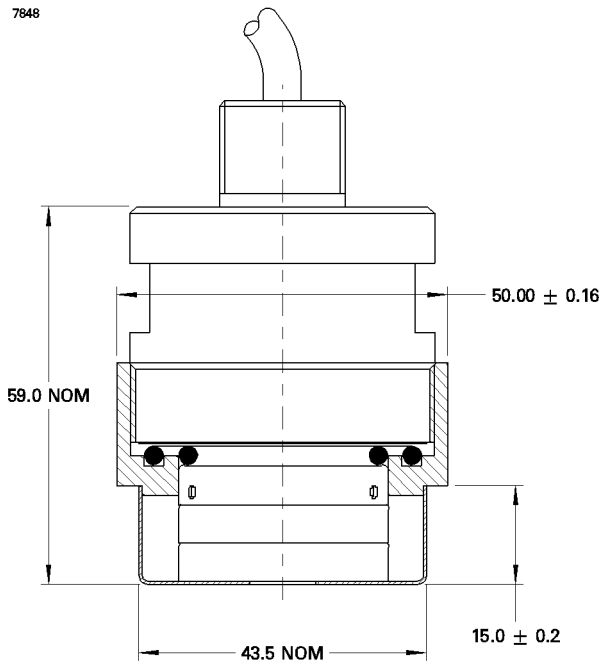

The Weather Cap protects the IR600 from water when used in external locations, where rain or spray could interfere with the safe working of the head, or in internal locations where water jets, sprays or hoses are used routinely for cleaning purposes, etc. The cap is made of 316 stainless steel and has been tested to IP64 for effectiveness, and also to ensure that it does not significantly affect the IR600's performance.

Quick Calibration Hood DPP546618DA

7850

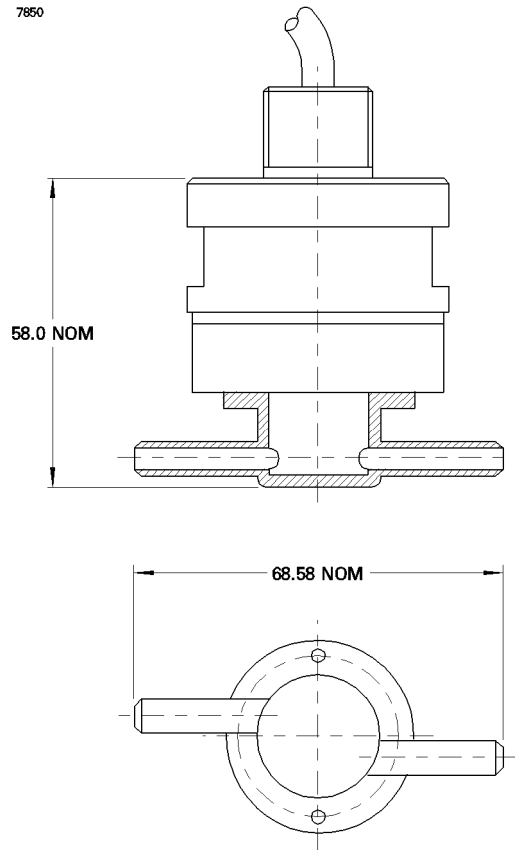

The Quick Calibration Hood is constructed from polypropylene, and provides a convenient means of supplying test gases to the IR600 in the field, for calibration and checking purposes. The assembly push-fits into the central gas access recess of the head, and is designed to accommodate 6 mm ID or 1/4" flexible tubing.

ORDERING INFORMATION

IR600 Series Sensors, TX600 Transmitter Boards and DX600 Display Boards may be ordered as individual items or as combinations.

The thread code must be included with a sensor order, e.g. IR601/1 for a carbon dioxide sensor with metric 20 x 1.5 mm mounting thread.

TX600 Transmitter Boards should be calibrated to specific IR600 Series Sensors.

When an IR600 Series Sensor is ordered with a factory calibrated TX600 Transmitter Board, the combination is referred to as a TX600 Series assembly.

For example, a customer requiring a TX600 Transmitter Board calibrated with an IR601/1 sensor should order:

TX601/1 (i.e. IR601/1 + TX600 = TX601/1).