

The data should be read in conjunction with the Magnetron Preamble and with British Standard BS9030 : 1971.

ABRIDGED DATA

Mechanically tuned pulse magnetron intended primarily for linear accelerators.

Frequency range

(cooling water 40 °C) 2993 to 3002 MHz

Peak output power 2.0 MW

Magnet separate

Output to no. 10 (WR284) waveguide
(72.14 x 34.04 mm internal)

Cooling water

The use of an isolator is recommended (see note 1)

GENERAL DATA

Electrical

Cathode indirectly heated

Heater voltage (see note 2) 8.5 V dc

Heater current 9.0 A

Peak heater starting current,
not to be exceeded 20 A max

Cathode pre-heating time
(minimum) 3.0 min

Mechanical

Overall dimensions see outline

Net weight 8 kg approx

Tuner revolutions to cover frequency range
(see note 3) 4.75

Mounting position (see note 4) any

Accessories

Electromagnet (see notes 5 and 6) MG6061/MG6062

Waveguide transition M4152S

Cooling

The magnetron is water cooled and has an integral water jacket. The recommended water flow is 5 litres per minute or more; a pressure of approximately 1.25 kg/cm² will be necessary to give this rate of flow. The outlet water temperature must not exceed 50 °C.



MAXIMUM AND MINIMUM RATINGS

(Absolute values)

These ratings cannot necessarily be used simultaneously, and no individual rating should be exceeded.

	Min	Max	
Magnetic field			
(see notes 5 and 7)	110.0	157.5	mT
	1100	1575	gauss
Heater voltage (see note 2)	8.0	10	V dc
Heater starting current (peak)	-	20	A
Anode voltage (peak)	-	47	kV
Anode current (peak)	60	100	A
Input power (mean)	-	5.0	kW
Pulse duration	-	5.0	µs
Rate of rise of voltage pulse			
(see note 8)	80	120	kV/µs
Outlet water temperature	-	50	°C
VSWR at output coupler			
(see note 1)	-	1.5:1	
Pressurising of waveguide			
(see note 9)	-	3.1 kg/cm ² g	

TEST CONDITIONS AND LIMITS

The magnetron is tested to comply with the following electrical specification.

Test Conditions

Magnetic field (see notes 5 and 7)	155.0 + 2.5 mT	
	1550 ± 25 gauss	
Heater voltage (for test)	0	V
Anode current (peak)	100	A
Duty cycle (see note 10)	0.001	
Pulse duration	5.0	µs
VSWR at output coupler	1.1:1	
Minimum rate of rise of voltage pulse		
(see note 8)	120	kV/µs

Limits

	Min	Max	
Anode voltage (peak)	40	46	kV
Output power (mean)			
(see note 11)	2.0	-	kW
Frequency (see notes 12, 13 and 14):			
lower end of tuning range †	-	2993	MHz
upper end of tuning range †	3002	-	MHz
RF bandwidth at 1/4 power	-	1.0	MHz
Frequency pulling (VSWR			
not less than 1.5:1)	-	7.0	MHz
Stability (see note 15)	-	0.5	%
Heater current			see note 16

† Inlet water at 40 °C.

LIFE TEST

The quality of all production is monitored by the random selection of tubes which are then life-tested under typical operation conditions. If the tube is to be operated under conditions other than those specified herein, e2v technologies should be consulted to verify that the life of the magnetron will not be impaired.

NOTES

1. It is recommended that the magnetron should be isolated from the load by means of an isolator of approved design. Information on the characteristics of a suitable isolator may be obtained from e2v technologies.

2. With no anode input power.

It is recommended that a DC power supply is used to operate the heater. Use of an AC supply may result in damage to the heater circuit. The use of an AC heater supply during HT operation may result in frequency modulation of the RF pulses. Contact e2v technologies for further information.

The heater voltage must be reduced within 5 seconds after the application of HT according to the schedule shown on page 4.

The magnetron heater must be protected against arcing by the use of a minimum capacitance of 4000 pF shunted across the heater directly at the input terminals; in some cases a capacitance as high as 2 µF may be necessary depending on the equipment design.

3. The tuner mechanism is driven by means of three tapped holes in the tuner knob (see outline drawing) via a flexible drive. The torque required is 0.7 kg-cm minimum; the torque applied must not exceed 5.0 kg-cm.

4. To minimise frequency deviation when the magnetron is rotated about a horizontal axis, this axis should be parallel to the axis of the tuner.

5. The magnetron is designed for use with a separate permanent magnet or electromagnet. The north seeking pole of the magnet must be adjacent to the cathode terminal, marked C. The position of the magnet must be adjusted so that the axis of the field is in line with the axis of the anode and is at right angles to the H plane of the system waveguide. The user is invited to consult e2v technologies on the choice of magnets.

6. The MG5125 can be used at lower power levels by reducing both the magnetic field (which controls the peak voltage) and the peak current (see graph); this is necessary for maintaining a good RF spectrum and constant impedance.

7. Using a small Hall effect probe, the magnetic field measured at each pole face of the magnet must be within the following limits.

(a) At the centre of the pole face and 37.287 mm from the surface, the field must be 155.0 ± 2.5 mT (1550 ± 25 gauss).

(b) At four or more points equispaced on a circle of 33 mm diameter concentric with the pole face and 6.35 mm from its surface, including a point nearest the back limb of the magnet, the field must be as follows. At all points the field must be between 9.0 and 27 mT (90 and 270 gauss) greater than the field measured at the centre of the pole face; the variation between the points must not exceed 13 mT (130 gauss).

8. Defined as the steepest tangent to the leading edge of the voltage pulse above 80% amplitude. Any capacitance in the viewing system must not exceed 6.0 pF.

- At the maximum pressure of 3.1 kg/cm² gauge the maximum leakage will be such that with an enclosed volume of 1 litre the pressure will not drop by more than 70 kPa in 7 days.

It is recommended that the pressurised arc suppressant gas used in the waveguide should contain no more helium than is typically found in air, i.e. 0.0005%.

- The various parameters are related by the formula:

$$P_i = i_{apk} \times v_{apk} \times Du$$

where P_i = mean input power in watts

i_{apk} = peak anode current in amperes

v_{apk} = peak anode voltage in volts

and Du = duty cycle.

- The maximum variation of mean output power when the magnetron is rotated through 360° around any axis of the magnetron will not be greater than 6%.
- The frequency of the magnetron will vary after the application of anode voltage. Typically the frequency will be 0.5 MHz high 20 seconds after switching on HT and 0.1 MHz high 5 minutes after switching on.
- With a water flow rate of 5.0 litres per minute.
- The maximum variation of frequency when the magnetron is rotated through 360° around any axis of the magnetron will not be greater than 1.0 MHz.
- With the magnetron operating into a VSWR of 1.15:1. Pulses are defined as missing when the RF energy level is less than 70% of the normal energy level in a 0.5% frequency range. Missing pulses are expressed as a percentage of the number of input pulses applied during the period of observation after a period of 10 minutes operation.
- Measured with heater voltage of 8.5 V and no anode input power, the heater current limits are 8.0 A minimum, 10.0 A maximum.

HEALTH AND SAFETY HAZARDS

e2v technologies magnetrons are safe to handle and operate, provided that the relevant precautions stated herein are observed. e2v technologies does not accept responsibility for damage or injury resulting from the use of electronic devices it produces. Equipment manufacturers and users must ensure that adequate precautions are taken. Appropriate warning labels and notices must be provided on equipments incorporating e2v technologies devices and in operating manuals.



High Voltage

Equipment must be designed so that personnel cannot come into contact with high voltage circuits. All high voltage circuits and terminals must be enclosed and fail-safe interlock switches must be fitted to disconnect the primary power supply and discharge all high voltage capacitors and other stored charges before allowing access. Interlock switches must not be bypassed to allow operation with access doors open.



RF Radiation

Personnel must not be exposed to excessive RF radiation. All RF connectors must be correctly fitted before operation so that no leakage of RF energy can occur and the RF output must be coupled efficiently to the load. It is particularly dangerous to look into open waveguide or coaxial feeders while the device is energised. Screening of the cathode sidearm of high power magnetrons may be necessary.



X-Ray Radiation

High voltage magnetrons emit a significant intensity of X-rays not only from the cathode sidearm but also from the output waveguide. These rays can constitute a health hazard unless adequate shielding for X-ray radiation is provided. This is a characteristic of all magnetrons and the X-rays emitted correspond to a voltage much higher than that of the anode.

HEATER VOLTAGE REDUCTION SCHEDULE

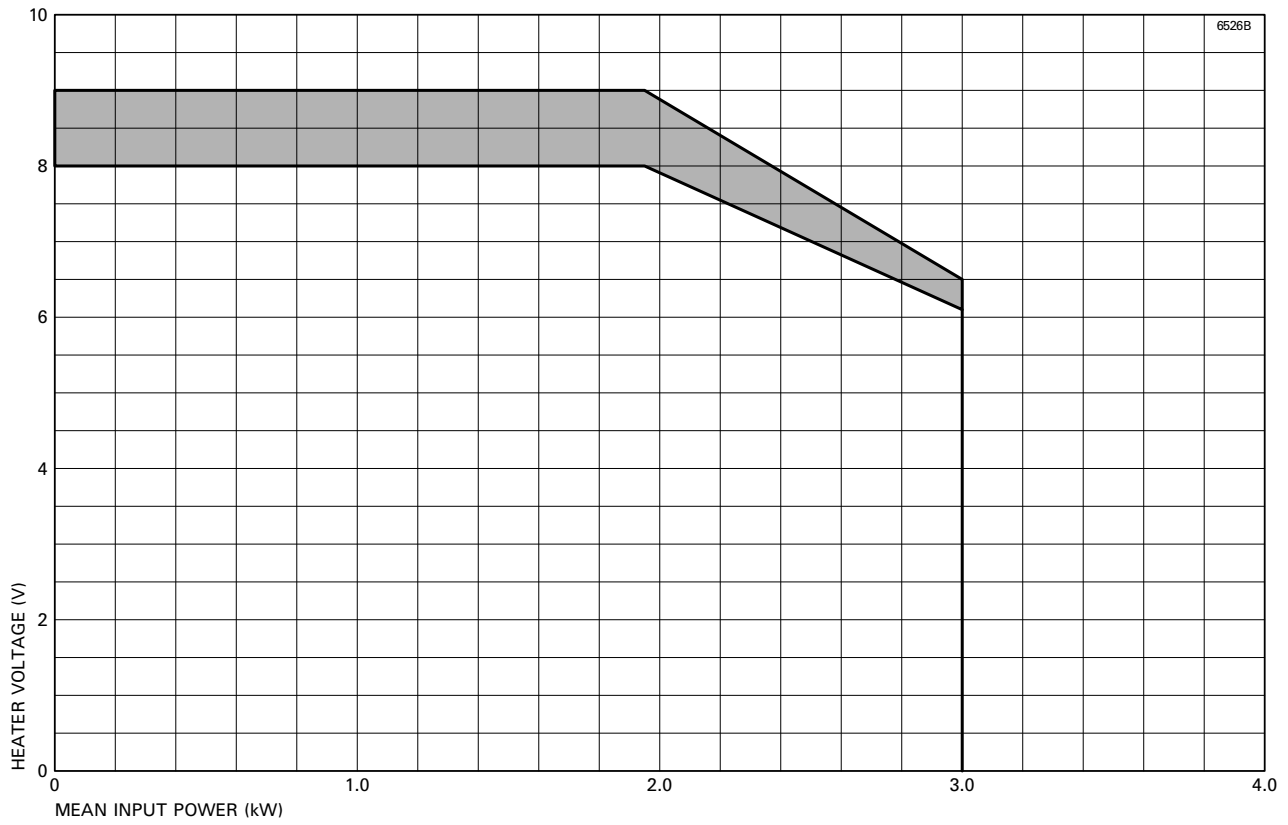

RECOMMENDED PARAMETERS FOR VARIOUS POWER LEVELS

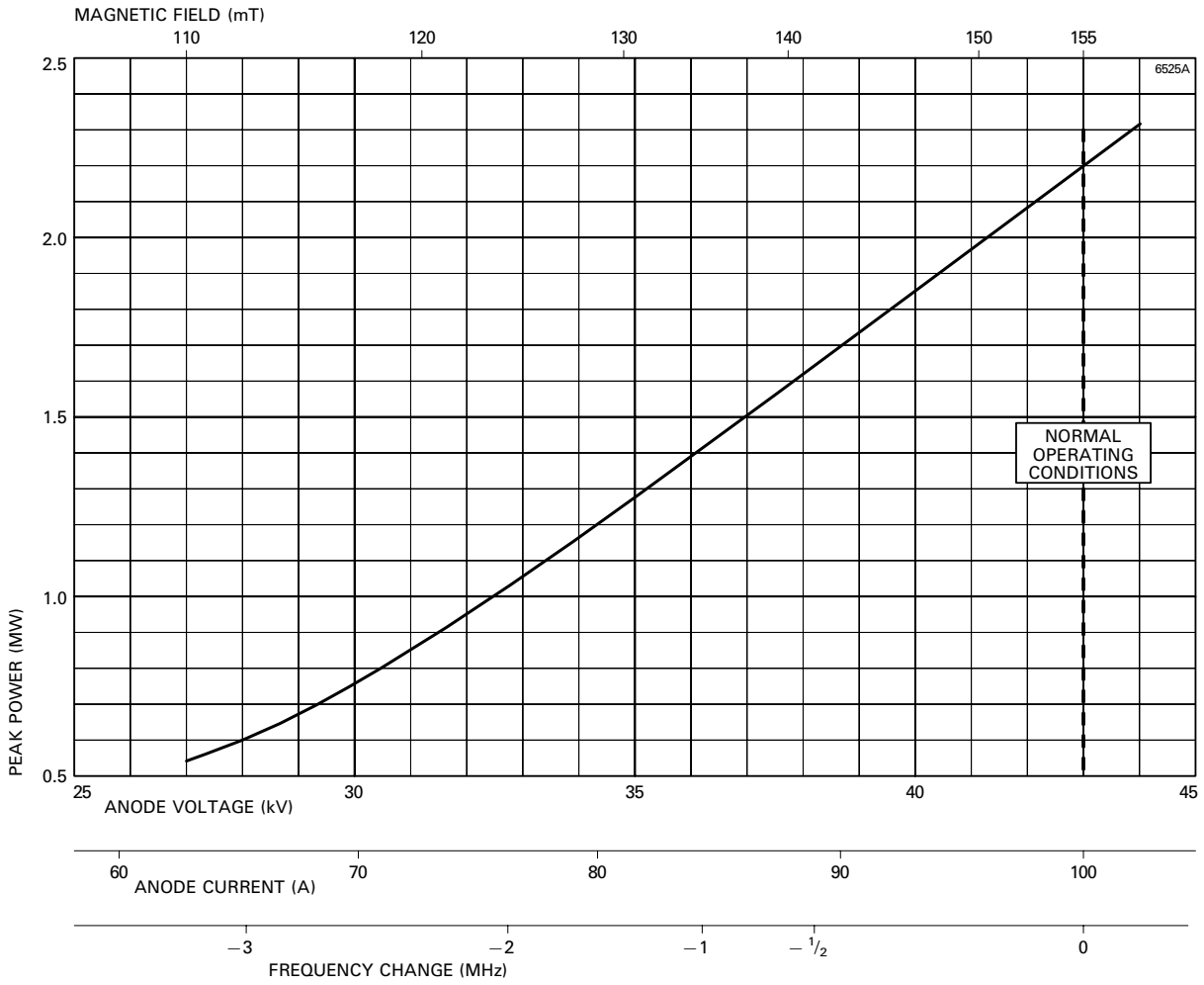

OUTLINE (All dimensions without limits are nominal)

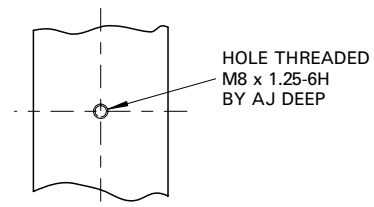
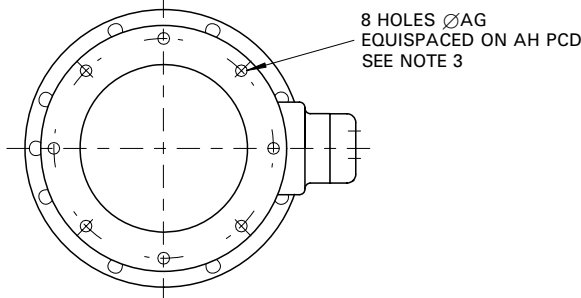
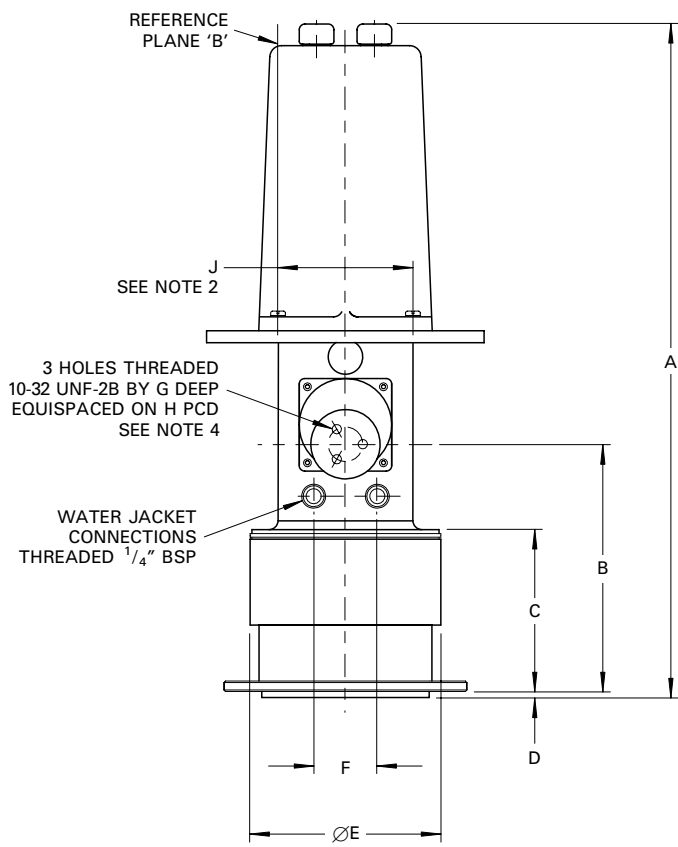
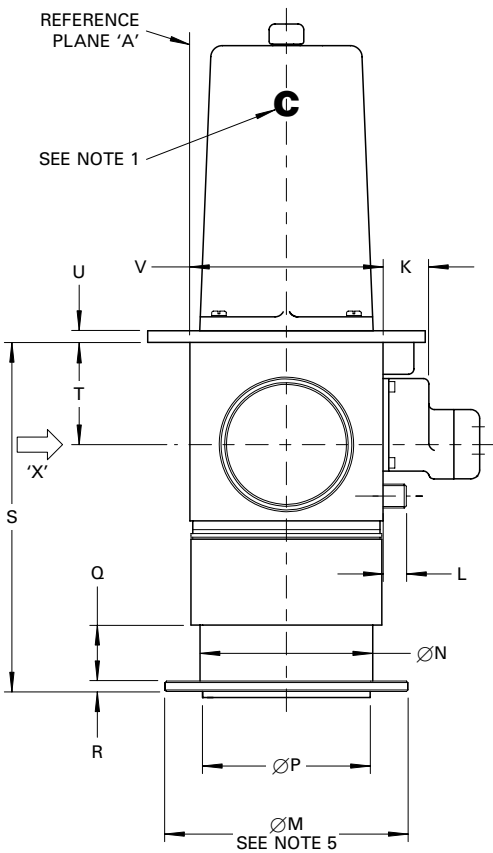
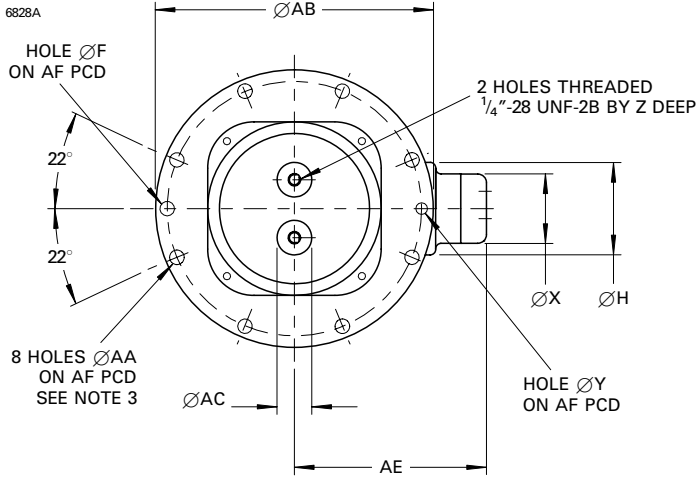

Scrap View in Direction 'X'

Ref	Millimetres
A	370.0
B	135.5
C	89.0
D	3.2
E	104.9
F	35.0
G	6.5
H	19.05
J	73.82 ± 0.20
K	25.0
L	12.5 ± 0.5
M	133.5
N	94.85
P	91.82
Q	5.55
R	31.4
S	191.5
T	55.96 ± 0.16
U	6.35 ± 0.10
V	107.0 ± 0.3
W	51.0
X	38.0
Y	6.40 ± 0.05
Z	6.0 max
AA	8.0 ± 0.1
AB	152.25
AC	19.0
AD	8.00 ± 0.05
AE	107.0
AF	139.7
AG	6.4 ± 0.1
AH	120.65 ± 0.13
AJ	15.0 max

Outline Notes

1. This surface is marked with the letter 'C' to indicate the cathode terminal.
2. The magnetron will fit between magnet poles 76.45 mm diameter and 75.44 mm apart.
3. Positional tolerance of holes 0.15 mm diameter.
4. Positional tolerance of holes 0.05 mm diameter.
5. Positional tolerance of flange 1.5 mm diameter with respect to reference planes A and B.

Whilst e2v technologies has taken care to ensure the accuracy of the information contained herein it accepts no responsibility for the consequences of any use thereof and also reserves the right to change the specification of goods without notice. e2v technologies accepts no liability beyond that set out in its standard conditions of sale in respect of infringement of third party patents arising from the use of tubes or other devices in accordance with information contained herein.