

The data to be read in conjunction with the Hydrogen Thyatron Preamble.

**ABRIDGED DATA**

Deuterium-filled tetrode thyatron with ceramic/metal envelope, featuring low jitter, firing time and drift. Suitable for switching high power at high pulse repetition rates or for switching long pulses. A deuterium reservoir operating from the heater supply is incorporated.

Peak forward anode voltage . . . . . 25 kV max  
 Peak anode current . . . . . 1000 A max  
 Average anode current . . . . . 1.25 A max

**GENERAL**

**Electrical**

Cathode (connected internally to one end of heater) . . . . . oxide coated  
 Cathode heater voltage . . . . . 6.3 ± 5% V  
 Cathode heater current . . . . . 14 A  
 Reservoir heater voltage (see note 1) . . . . . 6.3 ± 5% V  
 Reservoir heater current . . . . . 4.0 A  
 Tube heating time (minimum) . . . . . 5.0 min  
 Anode to grid 2 capacitance . . . . . 15 to 20 pF

**Mechanical**

Seated height . . . . . 123.8 mm (4.875 inches) max  
 Clearance required below mounting flange . . . . . 38.1 mm (1.500 inches) min  
 Overall diameter (mounting flange) . . . . . 88.9 mm (3.500 inches) nom  
 Net weight . . . . . 1.0 kg (2 1/4 pounds) approx  
 Mounting position (see note 2) . . . . . any  
 Tube connections . . . . . see outline

**Cooling** . . . . . forced-air or liquid  
 Liquid . . . . . oil or coolant immersion  
 Forced-air . . . . . see below

The tube may be cooled by forced-air directed mainly onto the base, and the ceramic envelope should be maintained below the maximum rated temperature. An air flow of at least 1.41 m<sup>3</sup>/min (50 ft<sup>3</sup>/min), depending on the mechanical layout, will be necessary to keep the tube operating temperatures under the limits specified below.

In addition to 120 W of heater power, the tube dissipates from 50 W per ampere average anode current, rising to 150 W/A at the highest rates of rise and fall of anode current.

The cathode end of the tube must be cooled whenever heater voltages are applied, since the cathode flange will reach a temperature of 120 °C above ambient in the absence of cooling.

Envelope temperature:  
 ceramic, anode and grid . . . . . 150 °C max  
 cathode flange and base . . . . . 120 °C max



**MAXIMUM AND MINIMUM RATINGS (Absolute values)**

These ratings cannot necessarily be used simultaneously, and no individual rating must be exceeded.

	Min	Typical	Max	
<b>Anode (Pulse Modulator Service)</b>				
Peak forward anode voltage . . . . .	-	-	25	kV
Peak inverse anode voltage (see note 3) . . . . .	-	-	25	kV
Peak anode current . . . . .	-	1000	-	A
Average anode current . . . . .	-	-	1.25	A
Rate of rise of anode current (see notes 4 and 5) . . . . .	-	5000	-	A/μs
Pulse repetition rate . . . . .	-	500	-	pps

## MAXIMUM AND MINIMUM RATINGS (Continued)

	Min	Max	
<b>Anode (Single-Shot, see note 6)</b>			
DC forward anode voltage . . . . .	-	20	kV
Peak anode current . . . . .	-	5	kA
Rate of rise of anode current . . . . .		see note 4	
Total conducted charge:			
capacitor discharge . . . . .	-	0.05	C
power supply follow-on . . . . .	-	2	C
Repetition frequency . . . . .	1 pulse per 10 s	max	

### Grid 2

Unloaded grid 2 drive pulse voltage (see note 7) . . . . .	200	1000	V
Grid 2 pulse duration . . . . .	1.0	-	μs
Rate of rise of grid 2 pulse (see note 5) . . . . .	10	-	kV/μs
Grid 2 pulse delay . . . . .	0.5	3.0	μs
Peak inverse grid 2 voltage . . . . .	-	450	V
Loaded grid 2 bias voltage . . . . .	-50	-200	V
Forward impedance of grid 2 drive circuit . . . . .	50	1000	Ω

### Grid 1 - Pulsed

Unloaded grid 1 drive pulse voltage (see note 7) . . . . .	300	1000	V
Grid 1 pulse duration . . . . .	2.0	-	μs
Rate of rise of grid 1 pulse (see note 5) . . . . .	1.0	-	kV/μs
Peak inverse grid 1 voltage . . . . .	-	450	V
Loaded grid 1 bias voltage . . . . .		see note 8	
Peak grid 1 drive current . . . . .	0.3	1.0	A

### Grid 1 - DC Primed (See note 6)

DC grid 1 unloaded priming voltage . . . . .	75	150	V
DC grid 1 priming current . . . . .	50	150	mA

### Cathode

Heater voltage . . . . .	6.3 ± 5%		V
Heating time . . . . .	5.0	-	min

### Reservoir

Heater voltage (see note 1) . . . . .	6.3 ± 5%		V
Heating time . . . . .	5.0	-	min

### Environmental

Ambient temperature . . . . .	-50	+90	°C
Altitude . . . . .	-	3	km
	-	10 000	ft

## CHARACTERISTICS

	Min	Typical	Max	
Critical DC anode voltage for conduction (see note 9) . . . . .	-	0.3	1.0	kV
Anode delay time (see notes 9 and 10) . . . . .	-	0.1	0.25	μs
Anode delay time drift (see notes 9 and 11) . . . . .	-	20	50	ns
Time jitter (see note 9) . . . . .	-	1.0	5.0	ns
Cathode heater current (at 6.3 V) . . . . .	12	14	16.0	A
Reservoir heater current (at 6.3 V) . . . . .	3.0	4.0	5.0	A

## NOTES

1. The reservoir heater must be decoupled with a suitable capacitor to avoid damage by spike voltages.
2. The tube must be mounted by means of its mounting flange.
3. The peak inverse voltage including spike must not exceed 10 kV for the first 25 μs after the anode pulse.
4. For single-shot or burst mode applications this parameter can exceed 100 kA/μs. The ultimate value which can be attained depends to a large extent upon the external circuit.
5. This rate of rise refers to that part of the leading edge of the pulse between 25% and 75% of the pulse amplitude.
6. When DC priming is used on grid 1, a negative bias of 100 to 200 V must be applied to grid 2 to ensure anode voltage hold-off. Also the higher grid 1 is pulsed, the larger the grid 2 negative bias must be to prevent the tube firing on the grid 1 pulse.
7. Measured with respect to cathode. Pre-pulsing grid 1 is recommended. The last 0.25 μs of the top of the grid 1 pulse must overlap the corresponding first 0.25 μs of the top of the delayed grid 2 pulse.
8. DC negative bias voltages must not be applied to grid 1. When grid 1 is pulse driven, the potential of grid 1 may vary between -10 V and +5 V with respect to cathode potential during the period between the completion of recovery and the commencement of the succeeding grid pulse.
9. Typical figures are obtained on test using conditions of minimum grid drive. Improved performance can be expected by increasing the grid drive.
10. The time interval between the instant when the unloaded grid 2 voltage passes cathode potential and the instant when anode conduction takes place.
11. The drift in delay time over a period from 10 seconds to 10 minutes after reaching full voltage.

## SCHEMATIC DIAGRAM

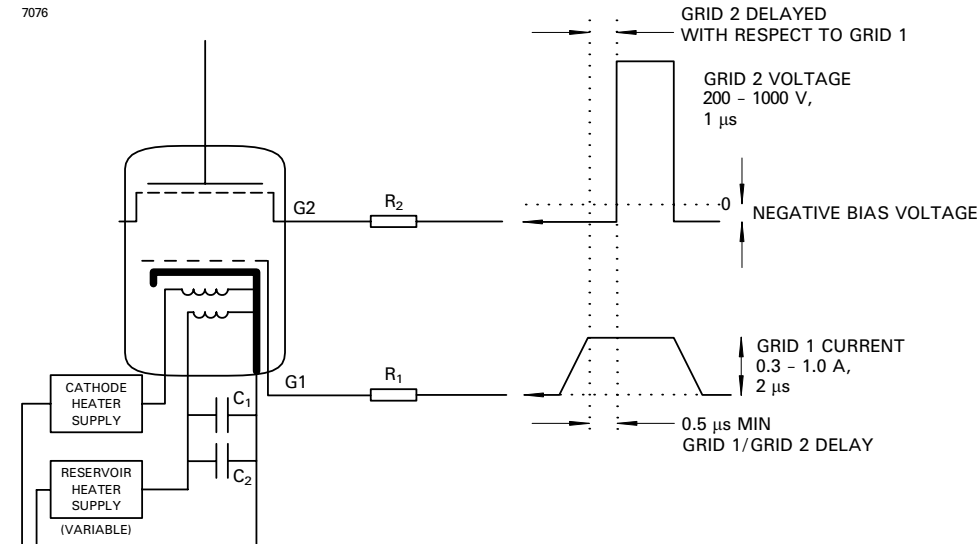

## RECOMMENDED GRID, CATHODE AND RESERVOIR HEATER CONNECTIONS

- $R_1$  = Grid 1 series resistor. 12 W vitreous enamelled wirewound is recommended, of a total impedance to match the grid 1 drive pulse circuit.
- $R_2$  = Grid 2 series resistor. 12 W vitreous enamelled wirewound is recommended, of an impedance to match the grid 2 drive pulse circuit.
- $C_1, C_2$  – reservoir protection capacitors with a voltage rating  $\geq 500$  V;
- $C_1$  = 1000 pF low inductance (e.g. ceramic),
- $C_2$  = 1  $\mu$ F (e.g. polycarbonate or polypropylene).
- Components  $R_1, R_2, C_1$  and  $C_2$  should be mounted as close to the tube as possible.

## HEALTH AND SAFETY HAZARDS

E2V Technologies hydrogen thyratrons are safe to handle and operate, provided that the relevant precautions stated herein are observed. E2V Technologies does not accept responsibility for damage or injury resulting from the use of electronic devices it produces. Equipment manufacturers and users must ensure that adequate precautions are taken. Appropriate warning labels and notices must be provided on equipments incorporating E2V Technologies devices and in operating manuals.



### High Voltage

Equipment must be designed so that personnel cannot come into contact with high voltage circuits. All high voltage circuits and terminals must be enclosed and fail-safe interlock switches

must be fitted to disconnect the primary power supply and discharge all high voltage capacitors and other stored charges before allowing access. Interlock switches must not be bypassed to allow operation with access doors open.



### X-Ray Radiation

All high voltage devices produce X-rays during operation and may require shielding. The X-ray radiation from hydrogen thyratrons is usually reduced to a safe level by enclosing the equipment or shielding the thyratron with at least 1.6 mm ( $1/16$  inch) thick steel panels.

Users and equipment manufacturers must check the radiation level under their maximum operating conditions.

# OUTLINE

(All dimensions without limits are nominal)

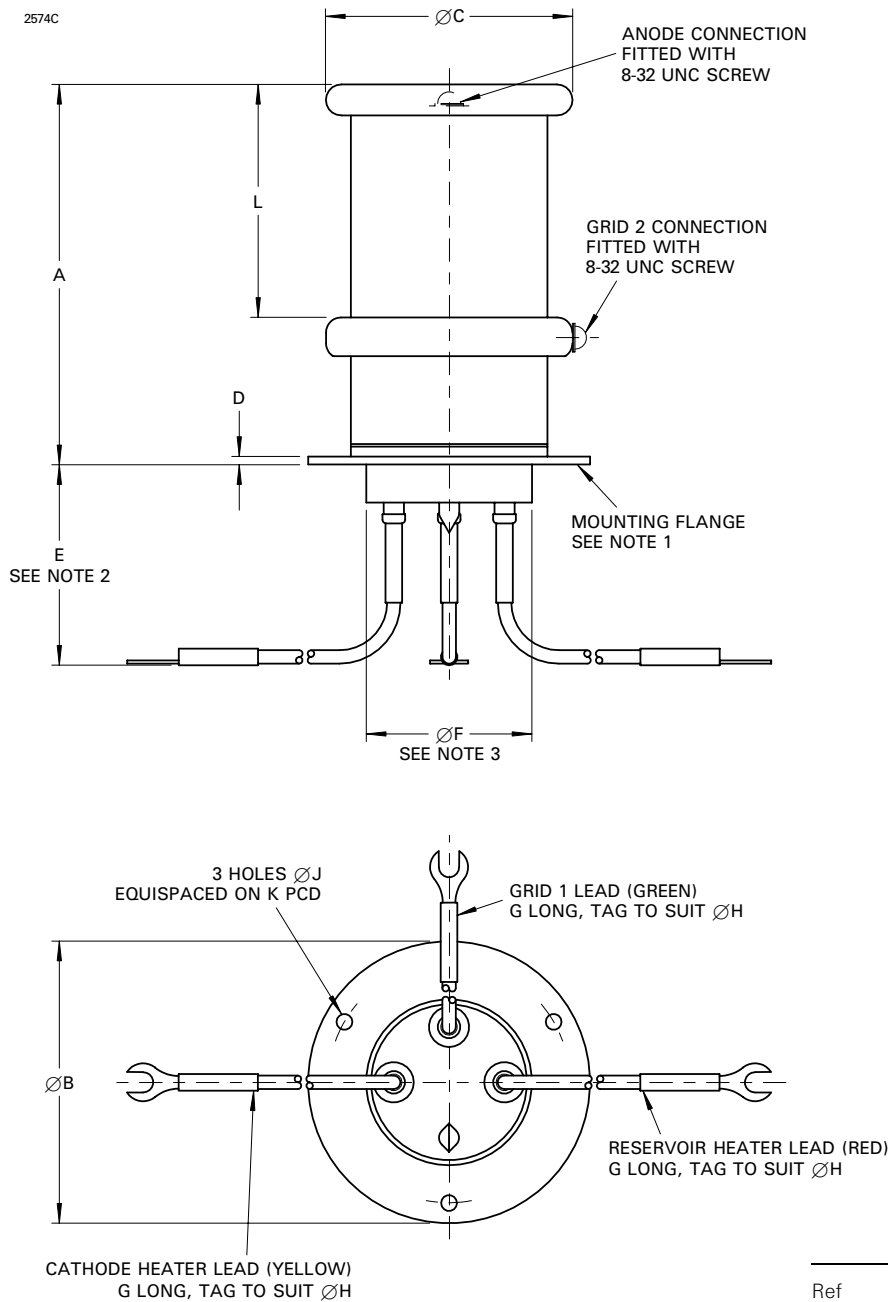

## Outline Notes

1. The mounting flange is the connection for the cathode, cathode heater return and reservoir heater return.
2. A minimum clearance of 38.1 mm (1.500 inches) must be allowed below the mounting flange.
3. The recommended mounting hole is 55.55 mm (2.187 inches) diameter.

Ref	Millimetres	Inches
A	123.8 max	4.875 max
B	88.9	3.500
C	77.77	3.062
D	2.54	0.100
E	38.1 min	1.500 min
F	53.98 max	2.125 max
G	152.4	6.000
H	6.35	0.250
J	5.0	0.197
K	76.2	3.000
L	73.03	2.875

Inch dimensions have been derived from millimetres.

Whilst E2V Technologies has taken care to ensure the accuracy of the information contained herein it accepts no responsibility for the consequences of any use thereof and also reserves the right to change the specification of goods without notice. E2V Technologies accepts no liability beyond that set out in its standard conditions of sale in respect of infringement of third party patents arising from the use of tubes or other devices in accordance with information contained herein.